

Sartoflow[®] 5000 SU

Commercial-Scale, Single-Use Tangential Flow Filtration System



Product Information

The Sartoflow[®] 5000 SU tangential flow filtration (TFF) system offers advanced controls and instrumentation for fully automated ultrafiltration (UF), diafiltration (DF), and microfiltration (MF) processes in biopharmaceutical production environments. Designed to handle batch volumes from 200–2,000 L, it combines superior performance and reliability within a compact footprint.

Benefits

- Performance – Maximize throughput with a pressure drop-optimized design and enhanced flow capacity.
- Adaptability – Improve system fit with modular options that align with diverse production demands.
- Ease of Use – Operate confidently with intuitive design and seamless system integration.

Relevant Applications

- Monoclonal antibodies (mAbs)
- Bioconjugates
- Vaccines
- pDNA and mRNA
- Recombinant proteins
- Viral vectors for gene therapy
- Biosimilars

Relevant Process Steps

- Ultrafiltration
- Diafiltration
- Microfiltration

System Concept

The Sartoflow® 5000 SU integrates hardware, a control system, and single-use flow kits to function cohesively. Its configurable design includes multiple options that enhance flexibility across different processes. The intelligently designed, easy-to-clean system provides clear visual guidance for consumables and features a user-friendly interface to ensure ease of use and minimize setup time. Fully automated TFF process sequences are supported by a single-use flow path, incorporating critical sensor and instrumentation technologies such as BioPAT® sensors and actuators, Biobrain® control software, and Flexsafe® Pro Mixers. Components in fluid contact are manufactured to withstand challenging conditions found in different modalities, such as bio-conjugation TFF processes, ensuring reliability and durability.

Maximized Performance

Optimal efficiency is supported by a scalable flow rate ranging up to 5,000 L/h, enabling high product concentrations and optimized recovery. The system accommodates up to 14 m² cassette area (21m² holder option available upon request), and hollow fiber modules up to 5 m², allowing for minimal working volume of approximately 6.9 L.

High Flexibility

Cassettes and hollow fiber modules can be interchanged seamlessly, to support a broad range of UF| DF and MF applications. A variety of configuration options are available to address specific process requirements.

Simplified Operations

The system is fully automated with pre-defined process recipes to enhance operational intelligence. Component accessibility has been optimized, and flow kit installation is typically completed in under 25 minutes.



Automation

Biobrain® is a modular automation platform purpose-built for the dynamic demands of up- and downstream processes. It combines robust industrial hardware and software with full traceability and flexible configuration, allowing for fast adaptation to evolving process requirements. With full OPC UA support for both monitoring and control, Biobrain® integrates seamlessly with higher-level systems such as DCS (e.g., DeltaV) and MES platforms, ensuring smooth interoperability across the plant. Designed to meet industry standards and the demands of Bioprocessing 4.0, Biobrain® enables faster deployment, simplified reconfiguration, and a future-proof digital foundation.

- One Software Platform: Biobrain® powers Sartorius solutions across various processes, ensuring cGMP readiness and compliance with industrial standards like GAMP 5, Cat 4, CFR21 Part 11, and ISA-88. Its high configurability reduces training efforts while features, security, and compatibility continue to evolve.
- Reliable Technology: Built on Siemens Simatic®¹ S7-1500 PLC and WinCC OA, Biobrain® ensures a reliable hardware foundation.
- Customizable Process Framework: Predefined TFF process phases and recipes enable the fast and reliable set-up of robust processes. The Biobrain® Recipe Editor offers flexible, user-friendly customization of existing recipes and the creation of user-specific operational sequences, ensuring tailored process solutions.

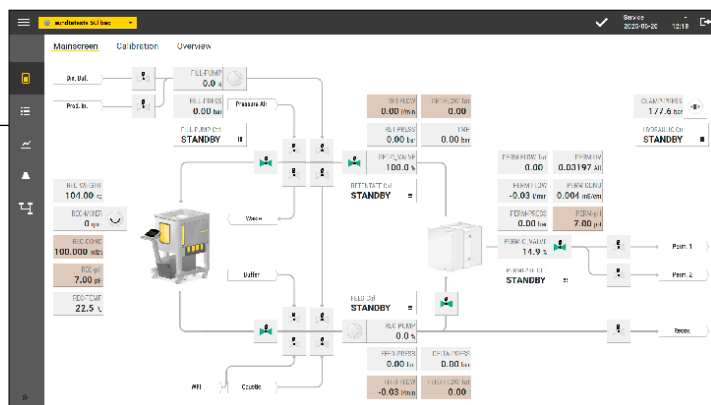

¹ Simatic is a registered trademark of Siemens AG.

Single-Use Flow Kit

The Sartoflow® Single-Use Flow Kit is carefully designed to integrate effortlessly with the Sartoflow® 5000 SU system, ensuring optimal performance and process reliability. Built around core components manufactured by Sartorius and carefully selected third-party providers, the flow kit adheres to common guidelines, guaranteeing suitability and quality.

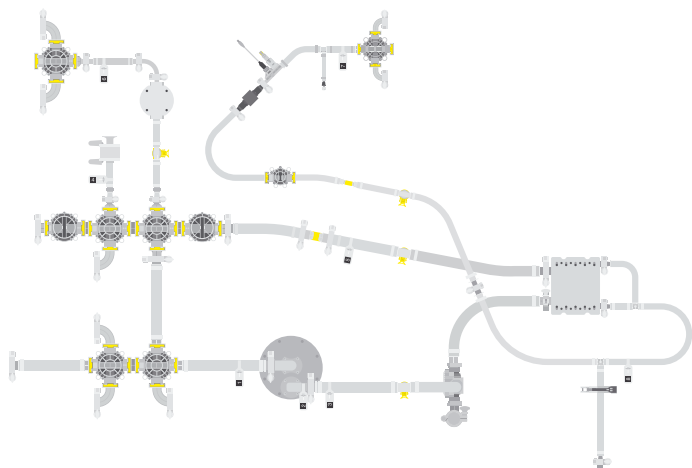

Innovative Multi-Block Valve Technology:

A novel multi-block valve technology reduces valve installation steps by 56%², streamlining process setup. The compact design minimizes dead-leg volume, optimizes space utilization, and supports consistent system operation.

Installation and Configuration:

Setup is streamlined through the easy installation of the single-use flow path, typically completed in under 25 minutes. A range of configurable options, including interfaces for various filter types, connectors, and sensors, supports adaptation to specific process needs.

Manufacturing Excellence:

The flow kits are produced in state-of-the-art clean room facilities certified to BS/EN/ISO 14644-1 Class 7, under a robust ISO 9001:2008 quality system. Rigorous monitoring for particulates and endotoxins, along with compliance with USP Class VI plastics specifications (USP<88>), ensures the high standards of quality and safety.

Single-Use Mixing Bags

The Flexsafe® Pro Mixer Bag, specifically designed for the Sartoflow® 5000 SU, combines ergonomic and innovative features for exceptional ease of handling.

Its unique side K-weld design simplifies installation and facilitates smooth unfolding and folding during filling and draining operations. Optimized tubing and sensor positioning ensure easy installation and direct access for filling, sampling, and draining. The levitating impeller, with high torque, efficiently mixes high-concentration and viscous solutions while minimizing shear effects.

Available in 50, 200, and 400 L sizes, the Flexsafe® single-use 3D mixing bags support efficient mixing and temperature control. An integrated sampling port and sensors for conductivity, pH (available at 200 and 400 L scale), and temperature allow continuous process monitoring.

² Compared to the Sartoflow® 4500.

Technical Specifications

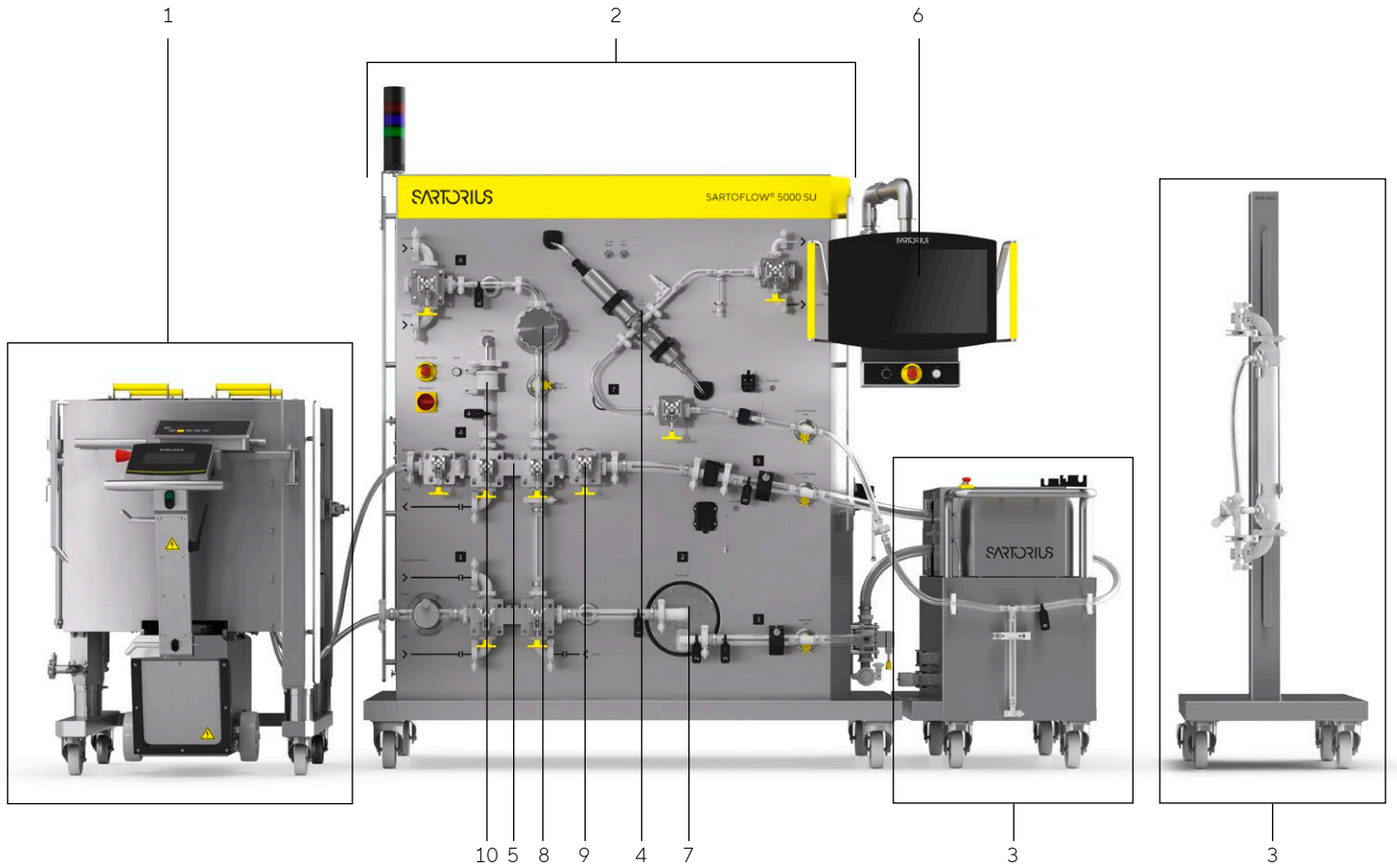

Material		Material	
1	Recirculation tank	6	22" Control screens
2	Basic unit	7	Recirculation pump
3	Universal cassette or HF holder trolley	8	Transfer pump
4	Permeate UV molecule guard	9	Retentate control valve
5	Multi block valves	10	System blow down

System Specification	
Membrane area cassettes	up to 14 m ² (optional up to 21 m ²) ³
Filter holder capacity (available space for cassettes)	Cassette holder up to 14 m ² : 469.9 (±2) mm optional up to 21 m ² : 769.9 (±2) mm
Membrane area of hollow fiber	up to 10 m ² (12", 24", 41") ³
Module diameter	51 - 120 mm up to 850 mm
Maximum pressure	4 bar
Volume in feed and retentate lines	3.3 L
Minimum working volume ²	
1. Concentration diafiltration	15.9 L
2. Final concentration	6.9 L
Recirculation vessel volumes	50 L, 200 L, 400 L (further sizes available upon request)
Mixing	Yes
Operating temperature. range	4 - 40 °C
Temperature. control range	10 - 40 °C
Hardware main construction material	AISI 304, stainless steel 1.4404, Ra ≤ 1.2 µm Non-wetted components such as pump motors, instrument transmitters, and controls are supplied using manufacturers' standard materials and protective coatings.
IP rating basic unit	IP54
Dimension (length × depth × height)	System basic unit: 185 × 92 × 196 cm
Weight	700 kg
	Cassette holder trolley (optional)
	Standard 60 × 119 × 91 cm 150 kg
	Automatic-hydraulic pump 63 × 129 × 96 cm 190 kg
	Hollow fiber holder trolley (optional) 60 × 72 × 195 cm 70 kg
	200 L tank single wall (optional) 111 × 120 × 100 cm 111 kg
	Mixer (optional) 167 × 147 × 80 cm 167 kg
Pneumatic supply	TC25 7.5 bar(g) (free from oil and particles)

³ The maximum filter area is dependent on process parameters and pump performance (e.g., <4 LMM at 21 m²). For process consultation, please contact your local Sartorius Field Application Specialist.

System Specification

Power supply	380 – 480V 50 60Hz Option 1: Legrand L2220-P Plug 5-Wire 20A 277/480V Turnlok® Option 2: Mennekes 13522 CEE Plug Xtra S 16A 5p 6h 400V IP54
Average energy consumption	0.92 kW
Optional transformer	U primary 3 × 200 – 230 V (±10%) U secondary 3 × 400 V I secondary 3 × 16 A 11 KVA or 37 KVA
Uninterruptible power supply (UPS)	24 VDC included (Ensure a hold status of min. 10 minutes and controlled shutdown)
SCADA connection	M12/4 plug type: D-coded

Component Specification

Recirculation pump	Flow rate range: 50 – 5,000 L/h 4-piston diaphragm pump
Fed batch buffer pump	Flow rate range: 6 – 1,200 L/h 4-piston diaphragm pump
Retentate control valve (TMP, retentate pressure, fixed position)	Yes
Permeate control valve (permeate pressure, permeate flow, fixed position)	Yes
Pressure measurement	Maximum operating range: 0 – 4 bar(g) Accuracy: 0 – 2 bar(g): 80 mbar(g) 2 – 4 bar(g): 4% c.v.
Flow measurement (retentate)	Max. flow rate: 77 L/min Accuracy 3 – 30%: 0.69 L/min Accuracy 30 – 100%: 3% c.v.
Flow measurement (permeate)	Max. flow rate: 20 L/min Accuracy 3 – 30%: 0.18 L/min Accuracy 30 – 100%: 3% c.v.
Temperature measurement (recirculation bag)	Range: 0 – 80 °C Accuracy: ±0.4 °C
Conductivity (inline permeate)	Range: 0 – 150 mS/cm Accuracy: 5% c.v.
Conductivity (recirculation bag)	Range: 0.1 – 200 mS/cm Accuracy: 3% of current value for 0.1100 mS/cm 5% of current value for 100 – 200 mS/cm
UV (inline permeate)	Range: ±0 – 2 AU (OPL 20mm) Accuracy: +/- 0.06 AU (OPL 20mm) Wavelengths (dual): 254 and 280 nm
pH (inline permeate)	pH range: 3 – 10 4 – 40 °C Accuracy: ±0.2 pH
pH (recirculation bag - 200 & 400L)	pH range: 3 – 10 4 – 50 °C Accuracy: ±0.1 pH

Component Specification	
Mass measurement (Example: 200 L tank)	Max. net capacity: 220 kg Resolution: 20 g
TCU	400 V; 3/PE; 50 Hz & 460 V; 3/PE; 60 Hz 7,5 kW – 10 kW heating; 5 kW cooling (dependent on refrigerant and temperature) Temperature control range: 10 – 40 °C
IT test	Optional Sartocheck® available
Components in Fluid Contact	
Components in Fluid Contact	Material of Construction
Tubing	Platinum cured silicone, reinforced in high pressure sections
Recirculation pump	Polypropylene head, EPDM valves and O-rings, Santoprene™ ⁴ diaphragm
Diafiltration fed batch pump	Polypropylene head, EPDM valves and O-rings, Santoprene™ ⁴ diaphragm
Connectors and fittings:	
▪ TC	Polypropylene, Polyethylene
▪ ASQ	Polycarbonate
▪ Clave	Acryl, PBT, silicone
▪ Fittings	Polypropylene
Gaskets	EPDM, Silicone
Diaphragm Valves	Polybutylene terephthalate, silicone
Distribution plate and closing plates	Polypropylene
Sensors:	
▪ UV	Polyphenylsulfon
▪ Pressure	Polybutylene terephthalate, silicone
▪ Flow	Polybutylene terephthalate
▪ pH-/conductivity (incl. temperature)	Polybutylene terephthalate, glass, ceramic, platinum, EPDM, LOCTITE® ⁵
▪ Conductivity (bag)	Polyethylene
▪ pH (bag)	HDPE, silicone O-rings
▪ Temperature (bag)	PE, silicone
Bag:	
▪ TC Version:	HDPE
▪ ASQ Version	Polycarbonate, polyethylene, silicon
▪ Impeller	Polyethylene
▪ Film	LLDPE

⁴ Santoprene™ is a trademark of Exxon Mobil Corporation.

⁵ LOCTITE® is a trademark of HENKEL IP & HOLDING GMBH.

Ordering Information

The Sartoflow® 5000 SU solution is a configure-to-order offering, tailored to meet your specific requirements. Please reach out to your local sales partner.

System	
Base Unit:	
<ul style="list-style-type: none">▪ Recirculation pump▪ Product buffer addition pump▪ Sensors: pressure, flow, conductivity, pH▪ Automated pneumatic multi-block valves▪ Software: Biobrain® Recipe tool	
Filter cassette holder for up to 14 m ² (manual or automated version)	Optional
Filter cassette holder for up to 21 m ² (manual version)	Optional
Hollow fiber holder for 12", 24", 41" modules	Optional
Temperature control unit	Optional
UV detection in permeate	Optional
Recirculation mixing vessel 50, 200, 400 L	Optional
Transformer 200 - 230V	Optional
Sartocheck®	Optional
Consumables	
3D Recirculation mixing bags	50 L 200 L 400 L (TC or AQ connector)
Single-use flow kits	TFF cassette <ul style="list-style-type: none">▪ TC Flow Kit (round or oval hole distributor plate UV optional)▪ AQ Flow Kit (UV and sterile claim optional) TFF hollow fiber <ul style="list-style-type: none">▪ TC Flow Kit (UV optional)
TFF cassettes and hollow fiber modules	A wide range of options available, please visit the Sartorius website: sartorius.com/en/products/process-filtration/tangential-flow-filtration

Germany

Sartorius Stedim Biotech GmbH
August-Spindler-Strasse 11
37079 Goettingen
Phone +49 551 308 0

USA

Sartorius Stedim North America Inc.
565 Johnson Avenue
Bohemia, NY 11716
Toll-Free +1 800 368 7178

 **For more information, visit**
www.sartorius.com

©2025 Sartorius. All rights reserved. Biobrain®, Turnlok®, Sartocheck® and Sartoflow® are registered trademarks of Sartorius or its subsidiaries.

LOCTITE® is a registered trademark of HENKEL IP & HOLDING GMBH.
All other third-party trademarks are the property of their respective owners.

For details on the registrations please refer to <https://www.sartorius.com/en/patents-and-trademarks>

Last modified: 09 | 2025