

BioPAT® Trace and BioPAT® Multi Trace

Online Measurement of
Multiple Parameters
From 1 to 4 Vessels

Benefits

- Real-time online monitoring of bioprocesses parameters
 - Glucose and lactate
 - Methanol or ethanol
- Enable automated parameter feed | bleed control capability
- Compact, space-saving design
- Room temperature stable biosensors
- Wide linear measuring range

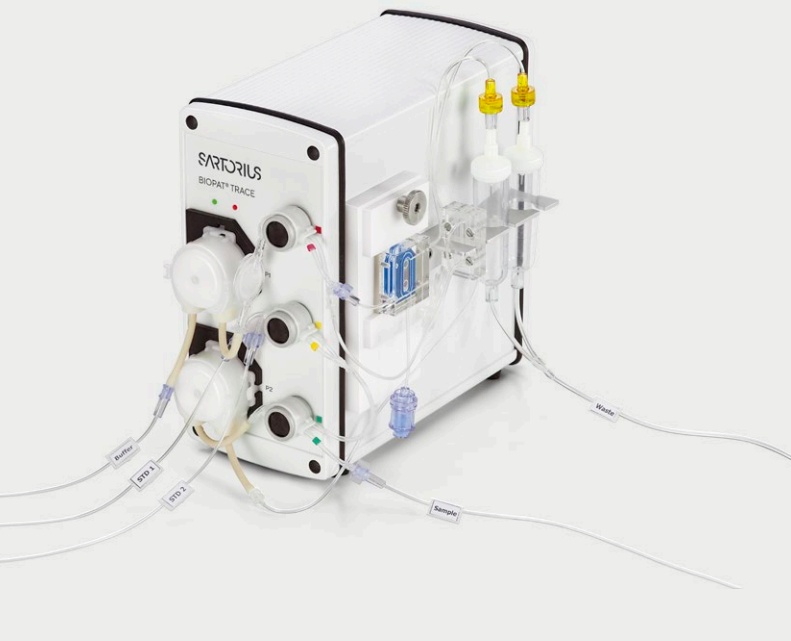

Product Information

The control of nutrients and metabolites starts by monitoring the parameter concentration and its rate of change. Once known, then an actuator (e.g. feed pump) can affect a change and bring the parameter to the desired set-point. BioPAT® Trace and BioPAT® Multi Trace enables this control to be automated without the need for operator intervention during the bioprocess.

BioPAT® Trace analysis platform is designed for simultaneous online monitoring of up to two parameters in any given setup. The biosensor components measure either glucose and lactate or small-molecule alcohols, such as methanol and ethanol. The system can be used for laboratory or industrial cultivations of microorganisms and mammalian cell lines.

BioPAT® Multi Trace has all the measurement functionality of the dedicated system yet is capable of sampling from up to four vessels without the need for operator intervention. The frequency, relative sample volume and accuracy of the parameter concentration data allows automated parameter control. This can be achieved by either actuating a feed pump or increasing the perfusion rate to influence parameter concentration and maintain a defined steady state.

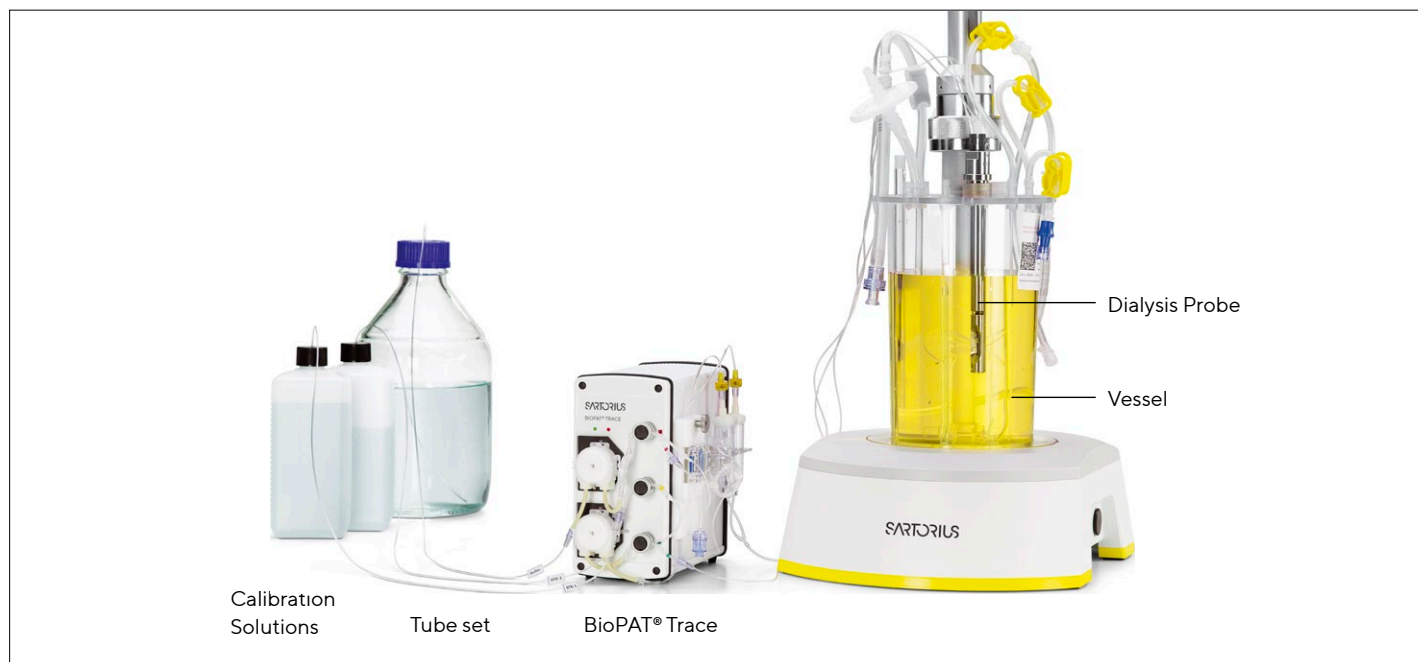

Figure 1: *BioPAT® Trace Practical Setup with Univessel® SU*

Measuring cell

The measuring cell contains the biosensors for glucose | lactate or methanol/ethanol (shown in the figure on the right). The 2-channel sensor is flowed vertically by the liquid (“wall-jet” principle). An air bubble-free percolation of the cell can be controlled through the viewing window. The electrical signal is measured through the electrodes and forwarded via the contact springs to the BioPAT® Trace | Multi Trace. A knurled nut is used to fix the measuring cell on the device.

Fluidics tube Set

To perform the sample analysis, a sample must be transported from the vessel to the biosensor. A complete fluidic setup consisting of 1–2 mm inner diameter tubing, peristaltic pump heads and ergonomically labeled connections is needed for every run. The BioPAT® Multi Trace tube set design has four sample lines which are controlled by automated pinch valves to sample from up to four different vessels.



Figure 2: *Image of the Measuring Cell*

Continuous Analysis

The BioPAT® Trace provides continuous parameter analysis with up to one data point per minute during cultivation. It is independent of the type of cultivation (batch, fed-batch, continuous cultivation) and allows the setup of automated parameter control loops. In addition to the online analysis function, scheduled or manually activated parameter calibrations during a batch ensure measurement robustness without stoppage.

Range

The linear measuring range of the BioPAT® Trace extends from

0.5 – 40 g/L	2.78 mM to 223 mM	Glucose
0.5 – 5 g/L	5.62 mM to 56 mM	Lactate
0.1 – 10 g/L	555 µM to 55 mM	Low glucose
0.05 – 2 g/L	562 µM to 22 mM	Low lactate
0.5 to 20 g/L	15 mM to 624 mM	Methanol
1 to 40 g/L	21 mM to 869 mM	Ethanol

BioPAT® Trace and Multi Trace require a minimum two-point calibration with known traceable parameter solutions to generate the linear measuring range. These calibration solutions are available from Sartorius Stedim Biotech.

Frequency

The measurement frequency of the BioPAT® Trace dialysis probe is up to 30 analyses per hour from a single vessel. The BioPAT® Multi Trace must perform additional flushing between vessel sampling and, therefore provides analyses every 7 minutes with four vessels connected. The next sequential data point generated for the first vessel is 28 minutes later.

If the required glucose|lactate concentration measured is below 0.1 g/L the accumulation time increases, resulting in biosensor data points every six minutes. This requires a BioPAT® Trace firmware update, with an optional change of the dialysis probe membrane to increase the permeability.

The BioPAT® Trace software can take scheduled samples at any given time point thus increasing or decreasing the sampling frequency to tailor it to specific process control requirements.

Duration

The service life of the biosensor is 30 days or 5,000 analyses depending on the application. The ambient temperature of the BioPAT® Trace can lie between 5 °C and 35 °C due to internal temperature correction. The ambient humidity should not exceed 90%.

Refer to the Glucose | Lactate: Performance and Accuracy application note for more details.

Accuracy

The deviation from the average measurement value is less than 3% for a measurement of 5 g/L glucose and 2.5 g/L lactate. Dynamic vessel temperature compensation of the biosensor and membrane diffusion is included if BioPAT® Trace is used with Biobrain® Supervise data acquisition.

Communication Integration

BioPAT® DCU Analog Connection

BioPAT® Trace has standard analog outputs in either voltage or milliamp signal ranges in order to connect it to the BioPAT® DCU and to show the two measured parameters. The BioPAT® DCU is configured to interoperate the signal over the fixed calibration range and show the two concentration values on the Biostat® visual display.

BioPAT® Multi Trace is not designed for analog connection to obtain the relevant data from all four vessels. Instead, digital connection is required.

Biobrain® Supervise digital connection

BioPAT® Trace and BioPAT® Multi Trace can be digitally connected by Modbus | OPC® to Biobrain® Supervise bioprocess management module with additional software from Sartorius Stedim Biotech. This option allows parameter data to be imputed directly into the supervisory control and data acquisition software for all sampled cultivations.

Connection options:

- Connection to MFCS/win 3.1 via OPC DA (separate OPC DA Server)
- Connection to MFCS/win 3.1 (SP4) via inbuild OPC UA server
- Connection to Biobrain® Supervise via inbuild OPC UA server

Mechanical Integration

Reliable Sampling

To analyze substrates in cultivation media, it is necessary for the sample to be taken from the vessel, while maintaining the sterile conditions within. The reproducibility and relevance of the sample taken must remain intact. The BioPAT® Trace has two sampling probe options available: dialysis and by-pass loop. All probe designs ensure aseptic removal from the vessel and transport to the biosensor module.

Dialysis Probe

This probe functions by time-dependent diffusion of sample across a 12 kDa permeable membrane. The transport buffer and vessel solution do not directly mix. However, during the BioPAT® Trace sampling cycle the transport buffer flow is paused and the concentration gradient drives small molecules from the bulk into the transport buffer. When flow is resumed after a set time period, this accumulated concentration is transported to the biosensor for analysis. This data is then correlated to the linear calibration to yield the bulk concentration.

- This sampling method uses the diffusion of small molecules across the permeable membrane without any loss of vessel volume.



Manual sample analysis

BioPAT® Trace systems enable a three-way stopcock to be conveniently integrated for manual sampling of off-line samples.

Calibration Solutions and Transport Buffer

BioPAT® Trace and BioPAT® Multi Trace require two calibration solutions and a transport buffer to function, and accurately determine the parameter concentration in a sampled vessel. These liquids are connected on the labeled end points of the tube set and are automatically pumped within the system loop. The calibration solutions include expiration dates to ensure the accuracy and longevity of the system analysis.

BPT0090	BioPAT® Trace buffer salt mixture CC Glc/Lac	5 pc
BPT0093	BioPAT® Trace Buffer solution Glc/Lac MO	2.0 L
BPT0092	BioPAT® Trace Buffer solution EtOH/MeOH	2.0 L
BPT0007	BioPAT® Trace Calibration solution 10g Glc/5 g Lac	0.5 L
BPT0008	BioPAT® Trace Calibration solution 4 g Glc/2 g Lac	0.5 L
BPT0009	BioPAT® Trace Calibration solution 2 g Glc/1 g Lac	0.5 L
BPT0010	BioPAT® Trace Calibration solution 1 g Glc/0.5 g Lac	0.5 L
BPT0011	BioPAT® Trace Calibration solution 0.5 g Glc/0.25 g Lac	0.5 L
BPT0041	BioPAT® Trace Calibration solution 20 g Glc/10 g Lac	0.5 L
BPT0043	BioPAT® Trace Calibration solution 0.1 g Glc/0.05 g Lac	0.5 L
BPT0051	BioPAT® Trace Calibration solution 0.2 g/L MeOH	0.5 L
BPT0052	BioPAT® Trace Calibration solution 1 g/L MeOH	0.5 L
BPT0053	BioPAT® Trace Calibration solution 5 g/L MeOH	0.5 L
BPT0054	BioPAT® Trace Calibration solution 20 g/L MeOH	0.5 L
BPT0055	BioPAT® Trace Calibration solution 40 g/L EtOH	0.5 L
BPT0056	BioPAT® Trace Calibration solution 4 g/L EtOH	0.5 L
BPT0057	BioPAT® Trace Calibration solution 2 g/L EtOH	0.5 L
BPT0058	BioPAT® Trace Calibration solution 0.5 g/L EtOH	0.5 L
BPT0044A	BioPAT® Trace Cleaning solution Methanol Ethanol	1.0 L
BPT0044G	BioPAT® Trace Cleaning solution Glucose Lactate	1.0 L

Technical Data

Specifications

BioPAT® Trace and BioPAT® Multi Trace

Measuring principle	Enzymatic amperometric		
Linear measuring range	Glucose	0.5 – 40 g/L	2.78 mM to 223 mM
	Lactate	0.5 – 5 g/L	5.62 mM to 56 mM
	Glucose low	0.1 – 10 g/L	555 µM to 55 mM
	Lactate low	0.05 – 2 g/L	562 µM to 22 mM
	Methanol	0.5 – 20 g/L	15 mM to 624 mM
	Ethanol	1 – 40 g/L	21 mM to 869 mM
Measurement deviation	Glucose Lactate	<1.5% 1 to 20 g/L <1.5% 1 to 10 g/L F.S.	
	Low Glucose Lactate	<2.5% 0.5 to 1 g/L <2.5% 1 to 0.5 g/L F.S.	
	Methanol	<2.0% 0.5 to 20 g/L	
	Ethanol	<2.0% 1.0 to 40 g/L	
pH range of the medium	4.8 – 9.2		
Service life of the enzyme electrode	Glucose Lactate	30 days or 5,000 analyses	
	Methanol or Ethanol	15 days or 5,000 analyses	
Operating temperature	15 °C to 35 °C (59 °F to 95 °F)		
Operating humidity	10 to 90%		
System storage conditions	5 °C to 60 °C (32 °F to 140 °F); 5% to 75% RH (non-condensing)		
Storage temperature	▪ Glucose Lactate biosensor	5 °C to 25 °C (41 °F to 77 °F)	
	▪ Alcohol biosensor	3 °C to 8 °C (37.4 °F to 46.4 °F)	

BioPAT® Multi Trace

Data frequency (with 4 vessel connected)	Dialysis	Up to 2 measurements/hr/vessel
Weight	2.0 kg	
Dimensions (W × H × D)	120 mm × 170 mm × 200 mm (4.7" × 6.7" × 7.9")	
Serial output	9-pin female connector to external pump	
USB interface	1× USB port (software updates only)	

BioPAT® Trace

Data frequency	Dialysis	Up to 30 measurements/hr
Weight	1.8 kg	
Dimensions (W×H×D)	120 mm × 170 mm × 200 mm (4.7" × 6.7" × 7.9")	
Analog output options	0 to 10 V 0 to 20 mA 4 to 20 mA	
Serial output	9-pin female connector to external pump	
USB interface	1× USB ports (software updates only)	

Connections

System communication interfaces	RS232, Ethernet
Communication cable length	Standard: 2 m (5 m and 10 m available)
Communication cable material	Non-metallic sheathed cable with finely stranded copper conductor; PVC insulation -40 °C to +70 °C (+40 °F to +158 °F)
Power supply	100 to 120 V 220 to 240 V ~; 50 60 Hz

Liquid | Waste Requirements

Transport buffer consumption	1.5 L/day to 2.0 L/day
Calibration solution consumption	5 mL/day to 145 mL/day
Fluid temperature	15 °C to 35 °C (59 °F to 95 °F)
Collection of waste liquid	Separate container required

BioPAT® Trace Dialysis Probe

Mechanical port connection	Diameter: 12 mm thread: steel conduit, PG 13.5	
Insertion depth Univessel® volume	132 mm 0.5 L	BPT0082
	165 mm	BPT0083
	212 mm ½ L	BPT0084
	232 mm 2 L	BPT0085
	332 mm 5 L	BPT0087
	432 mm 10 L	BPT0088
Port adapter insert depth reduction	19/12 mm 49 mm	BB-8848630
	25/12 mm 52 mm	BB-34165225
Product contact materials	1.4404 AISI - 316L stainless steel - Mechanically polished	
Construction material	Dialysis membrane: Cellulose acetate, approx. 12 kDa MWCO ² Pressure range: 0.8 bar to 3.4 bar 11.6 psi to 49.91 psi absolute pressure	
Port gasket	O-ring, 11 × 3 mm EPDM (FDA USP Class VI)	
Vessel preparation requirements	install membrane - fill buffer - autoclave steam sterilization	

BioPAT® Trace tube set for Dialysis

BioPAT® Trace

▪ Inlets	3
▪ Sample return loops	1
▪ Outlets	1

BioPAT® Multi Trace

▪ Inlet	3
▪ Sample return loops	4
▪ Outlets	1

Tube sets for BioPAT® Trace

▪ Glc Lac	BPT0089 and BPT0091
▪ MeOH EtOH	BPT0050 and BPT0048

Tube sets for BioPAT® Multi Trace

▪ Glc Lac	BPT0M07 and BPT0091
▪ MeOH EtOH	BPT0048

BioPAT® Trace tube set for Dialysis

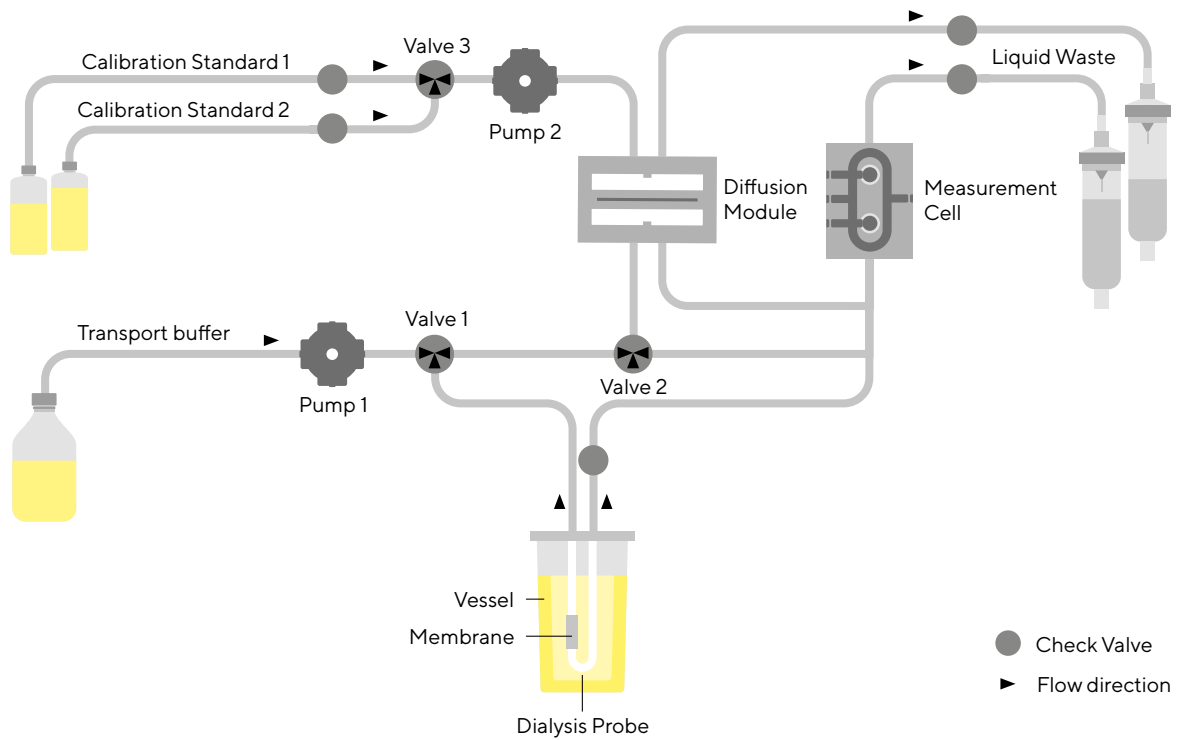

BioPAT® Multi Trace tube set for Dialysis

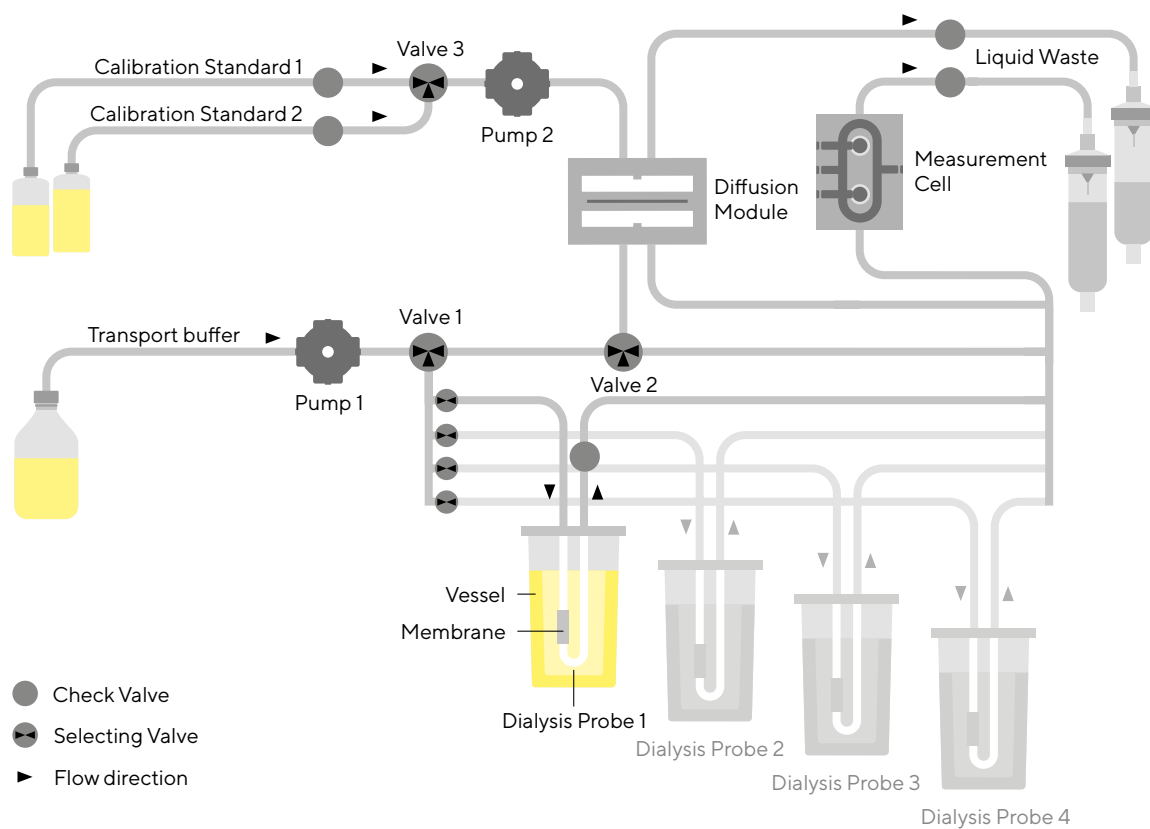

Germany

Sartorius Stedim Biotech GmbH
August-Spindler-Strasse 11
37079 Goettingen
Phone +49 551 308 0

USA

Sartorius Stedim North America Inc.
565 Johnson Avenue
Bohemia, NY 11716
Toll-Free +1 800 368 7178

🌐 For further contacts, visit

www.sartorius.com

Specifications subject to change without notice.
©2025 Sartorius Stedim Biotech GmbH, August-Spindler-Strasse 11, 37079 Goettingen, Germany

Publication No.: SLL2006-e
Order No.: 85032-541-03
Last Edited: 06 | 2025