

BioPAT® Spectro UV

Unlocking the Potential
of Single-Use Inline UV
Absorbance Monitoring for
Flexibility and Performance



Product Information

The BioPAT® Spectro UV family offers a new perspective on UV light absorbance measurements in single-use biomanufacturing processes. Unlike most of the alternatives on the market, which restrict the absorbance values to discrete wavelengths, BioPAT® Spectro UV makes the entire light absorbance spectrum between 190 nm and 390 nm continuously available.

Features and Benefits

- Full spectrum (190–390 nm): The appropriate wavelength is continuously available for diverse target molecules and process steps
- Performance: Low quantification limits without compromising the linear quantification range
- Scalable and flexible solution: The hardware remains consistent across single-use component sizes, eliminating the need for pre-configuration
- Powered by SIMCA®: When univariate data is not enough, advanced multivariate models can be generated and uploaded to the system

Introduction

Benefits of Using the BioPAT® Spectro UV

Functional and Optimized Consumable Design

The BioPAT® Spectro UV single-use pipe is designed to minimize dead volume without impacting fluid dynamics and avoiding a significant pressure drop across the flow path.

Fixed 1 mm Path Length

The optical path length (OPL) is fixed for all single-use pipe sizes independent of the inner diameter of the tubing assembly. This is achieved through a state-of-the-art manufacturing technique of the quartz cell, which ensures a reproducible and easy-to-assemble, single-piece component.

BioPAT® Platform

From material choice to product qualification or integrity control during manufacturing, the BioPAT® Spectro UV builds on the BioPAT® platform for easier implementation and validation within the bioprocess.

Compact One-Size-Fits-All Solution for Reliable and Reproducible Measurements

The mechanical interface of the BioPAT® Spectro UV probe head fits all sizes of the single-use pipe and calibration pipe, and its compact design assures a small footprint in the integration. The fine alignment of optical components inside the probe head coupled with the tight tolerances of the quartz cell dimensions contribute to the high reproducibility and comparability of the measurements.

Wavelength Range From 190 to 390 nm Is Always Available

The entire spectrum of light absorption between 190 and 390 nm is captured and can be transmitted with a sampling rate of up to 10 Hz. Discrete wavelengths can also be chosen and segregated by the control software of the integration system without the need for permanent pre-configuration of the BioPAT® Spectro UV hardware.

More Process Flexibility, Broader Linear Quantification Range

The combination of OPL, optics, and spectral data extends the range of quantification BioPAT® Spectro UV offers as a solution. The linear quantification range at discrete wavelengths is considerably extended without changing OPL or compromising on LOD/LOQ. MVDA models extend the quantification capabilities using spectral data.

Digital Interface and SIMCA®-Q

BioPAT® Spectro UV offers Profinet® as a digital communication interface. This enables a comprehensive integration of the spectrometer into the system of choice with better signal, data, and process management. Multi-variate data analysis (MVDA) powered by SIMCA®-Q is embedded into the spectrometer.

BioPAT® Spectro UV Components

The BioPAT® Spectro UV solution consists of three main components: the single-use pipe, the re-usable probe head, and a spectrometer (Figure 1). The single-use pipe is easy and quick to integrate into any single-use tube assembly. It is then connected to the probe head with a simple and reliable fixing mechanism. The light fiber cables forward the light from and back to the spectrometer, which also performs preliminary signal treatment.

Optionally, a BioPAT® Spectro UV Calibration Pipe and target molecule solutions of known concentration can be used to create a calibration curve | model that correlates the absorption signal | spectra to the analyte concentration (Figure 7).

Figure 1: BioPAT® Spectro UV Solution

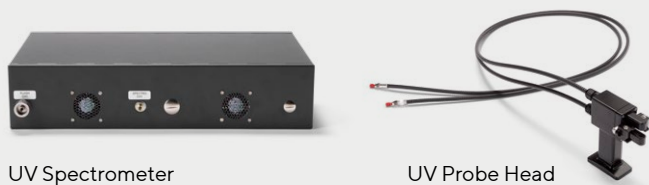

+



Single-Use UV Pipe



Calibration UV Pipe (optional)

=



BioPAT® Spectro UV Sensor

Note. The solution combines single-use and multi-use hardware, consisting of the probe head and the spectrometer. The calibration pipe can be used to create quantification models prior to the process runs.

Working | Measurement Principle

BioPAT® Spectro UV measures the absorbance of ultraviolet light, which can be used for qualitative and quantitative analysis of target molecules in solutions. The Beer-Lambert Law states that absorbance, at any given wavelength, is determined by the decimal logarithm of the ratio between transmitted and incident light or the product of the OPL, the concentration of the analyte, and its specific extinction coefficient (Figure 2).

Absorbance can be plotted against the wavelength, resulting in what we know as an absorption spectrum (in this case, an UV absorption spectrum). The measured spectrum is a weighted combination of the absorbance contributions from all present components (Figure 3).

Traditionally, the measurement is restricted to pre-configured discrete wavelengths and OPL to determine the unknown concentration of the analyte of interest, providing there is a known extinction coefficient.

BioPAT® Spectro UV uses a fixed 1 mm path length but captures the entire spectrum between 190 – 390 nm and makes it available for further processing. This leaves it open to the user or integration systems to select discrete wavelengths or the entire spectrum, which, combined with an MVDA software like SIMCA®, unfolds the full potential of this measurement.

Figure 2: Working Principle for UV Absorption Measurements: Beer-Lambert Law

Beer-Lambert Law: $A = \epsilon lc = \log \frac{E_0}{E}$

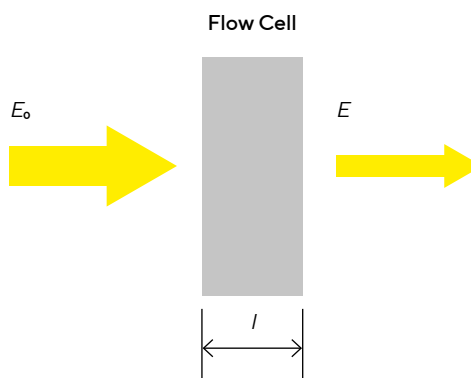

Note. A: absorbance, ϵ : extinction coefficient, l: optical path length, c: concentration, E_0 : incident light intensity, E: transmitted light intensity.

Figure 3: UV Absorption Spectra Example

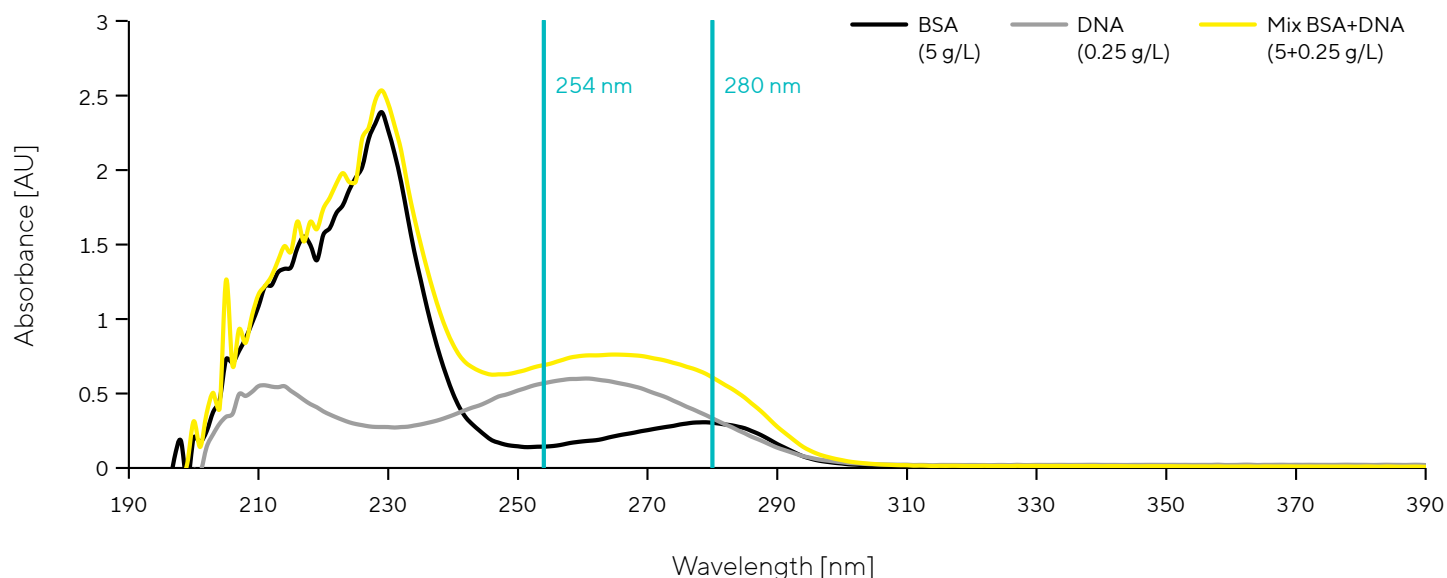

Note. Example of absorption spectra, between 195 to 390 nm wavelengths, collected with BioPAT® Spectro UV for model solution of pure protein (BSA), pure DNA (salmon sperm DNA) and a mixed solution of both.

Installation Recommendation

The presence of air bubbles disturbs the UV measurement; it is recommended that the probe head is installed so that the BioPAT® Spectro single-use pipe is at a 10°–45° angle (top upwards) to avoid them. The air bubbles are guided away from the quartz cell in this position (Figure 4).

Figure 4: BioPAT® Spectro UV Installation Guidance

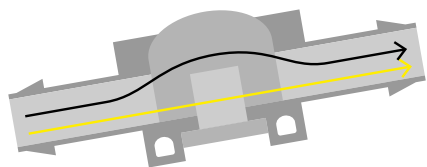

Note. Complying with the recommended good practices for installation of the BioPAT® Spectro UV minimizes measurement disturbances created by air bubbles.

Data Read-Out and MVDA Modeling

BioPAT® Spectro UV uses Profinet®, an industry standard for data communication and instrument control that facilitates its integration into modern bioprocessing facilities (both Sartorius and third-party systems). More independent installations, for example, in-process development applications, are supported by the integration into Biobrain® Supervise (coming soon). This solution also supports MVDA process model building, monitoring, and prediction. The spectral data can be exported as a SIMCA®-compatible.txt file to construct the model(s). These models can be uploaded to the spectrometer, with embedded SIMCA®-Q, for online monitoring and prediction.

Qualification and Quality Assurance

All products in the BioPAT® Spectro UV family comply with the quality and safety requirements of typical biopharmaceutical processes. Full batch traceability and quality control ensure that the single-use components follow the directives and guidelines of the relevant regulatory agencies. The same applies to the hardware components. A comprehensive analysis procedure includes, among others:

- extractable studies
- RoHs/REACH compliance
- non-cytotoxicity
- CE and UKCA conformity (hardware)

The BioPAT® Spectro UV Verification Kit (Figure 5) accommodates the regulatory requirements from USP <857> and Eur. Ph. Chapter 2.2.25, which guide the qualification of instruments for UV-Vis spectrophotometry.

Figure 5: BioPAT® Spectro UV Verification Kit



Note. The verification kit consists of a cuvette fixture, which clicks easily onto the BioPAT® Spectro UV probe head. A set of liquid standards allow users to carry out the required tests to regularly verify the spectrometer's performance according to USP <857> and Eur. Ph. Chapter 2.2.25.

Performance

Ranges and Limits

The BioPAT® Spectro UV Spectrometer is available with either one or two channels. Each channel has a separate internal reference system that allows for background subtraction, noise correction, etc., contributing to the excellent reproducibility of the measurement while maintaining a very high light intensity and outstanding measurement frequency.

The qualification of BioPAT® Spectro UV could not account for the diversity of molecules present in a biomanufacturing process. Still, using model substances provides a first insight into the technique's performance. It also showed that process parameters such as flow rate, pressure, or temperature do not impact the measurement.

When determining the limits of detection (LOD) and quantification (LOQ = 3 × LOD), the wavelength is chosen so that the absorbance of the molecule of interest is at maximum (Figure 6).

Prior to integration, similar tests can be carried out that suit the specificity and the goals of the particular use case, including the construction of a calibration model (univariate or multivariate) using the BioPAT® Spectro UV calibration pipe (Figure 1).

Figure 6: Limits of Detection and Quantification of BioPAT® Spectro UV

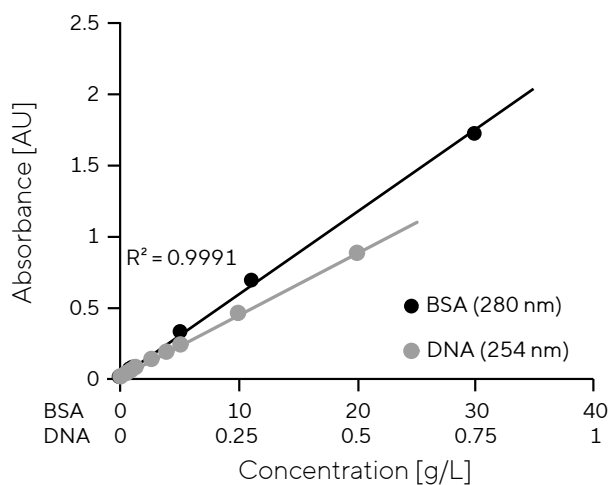

	LOD	LOQ
BSA	30 mg/L	100 mg/L
DNA	4 mg/L	11 mg/L

AU - absorbance units, SU - single-use

Note. Determined for model solutions of pure protein and DNA (see Figure 3).

For defining the upper limit for a linear quantification, the range considers the wavelength on the shoulder of the absorption peak (Figure 7).

Figure 7: Linear Quantification Range from BioPAT® Spectro UV

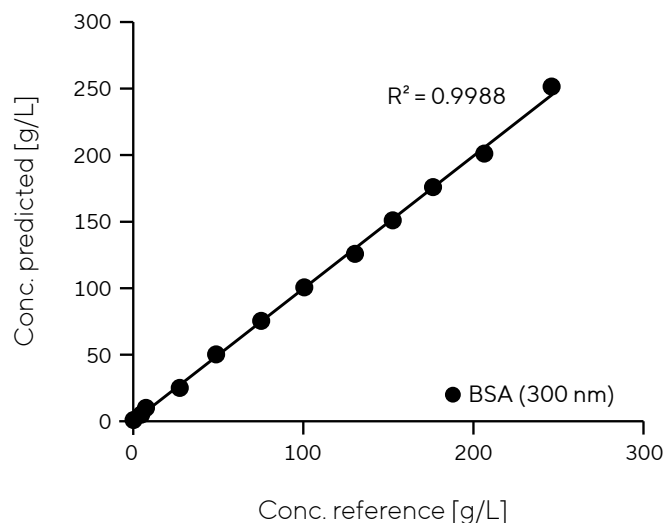

Note. Determined, at 300 nm, for a model solution of pure protein (see Figure 3).

Relevant Applications

Due to the acquisition rate, the BioPAT® Spectro UV is most suited as an in-line sensor for live monitoring of purification processes.

Chromatography

Figure 8 shows how BioPAT® Spectro UV can be used to monitor pre- and post-chromatographic matrix and quantify the target molecules concentration in the elution pool of an affinity chromatography step.

Figure 8: BioPAT® Spectro UV – Chromatography Application

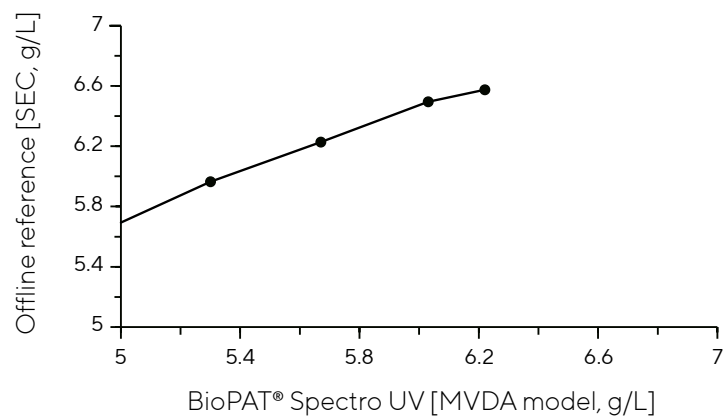
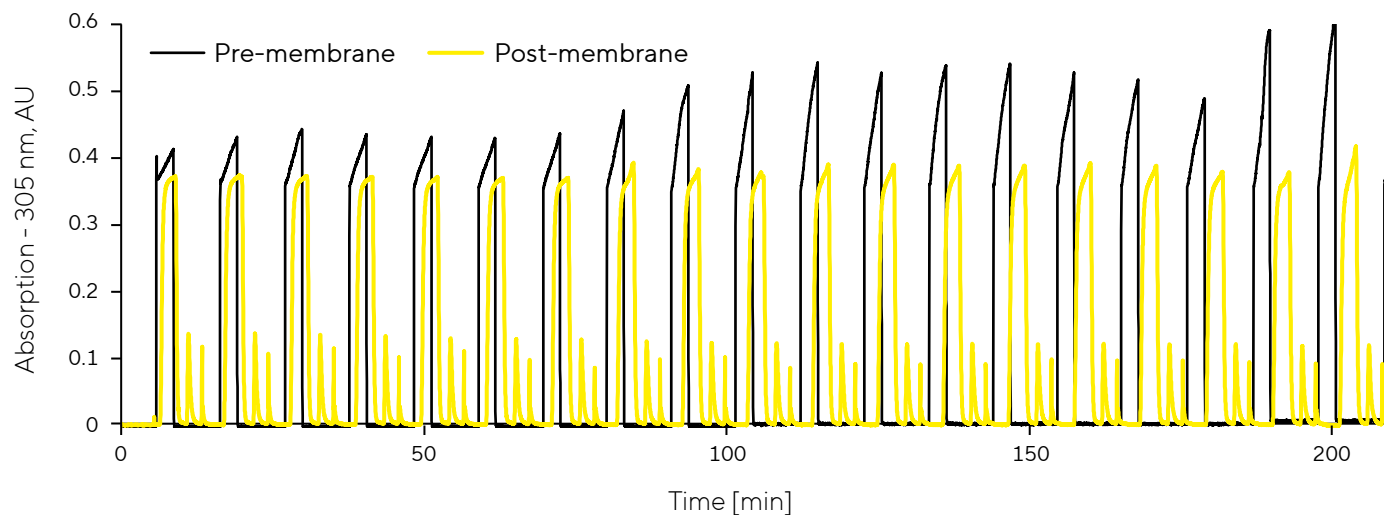

Note. Top: Monitoring (at 305 nm) of the inlet (black) and outlet (yellow) of a membrane absorber during an affinity chromatography purification (sequential batches, 20 cycles) of a model mAb. Bottom: The MVDA model is successful in the prediction of the reference value from the off-line analytical method.

Concentration & Buffer Exchange

Figure 9 shows how BioPAT® Spectro UV can be used to quantify the target molecule concentration in the retentate line.

Figure 9: BioPAT® Spectro UV—Concentration | Buffer Exchange Application

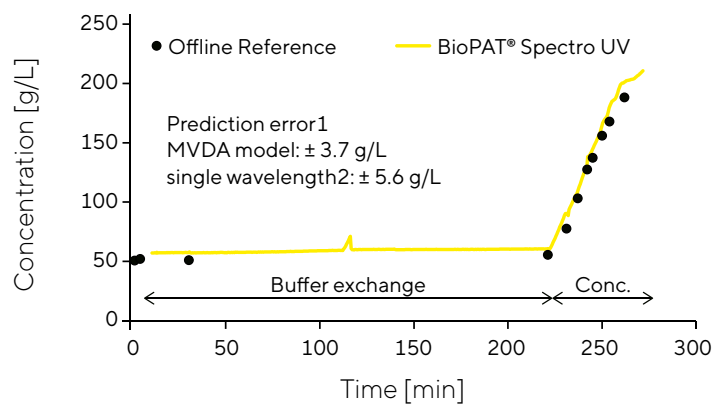

Note. Monitoring of the concentration of a model mAb in the retentate line of a buffer exchange and concentration process. The concentration was predicted with an MVDA model, which achieves a lower prediction error than a linear regression model with a discrete wavelength (300 nm).

A comprehensive integration of BioPAT® Spectro UV enables more advanced automated process control strategies. Furthermore, synergies with data analytics software, for example, from the Umetrics® suite, contributes to more robust modeling (Figure 8 and 9) and prediction of the processes. As a result, this solution should help alleviate the need for frequent off-line analytics.



Technical Specifications

Single-Use Pipes

Material	In contact with the product: PBT (polybutylene terephthalate), Quartz , EPDM (ethylene propylene diene terpolymer) Other: ABS (acrylonitrile butadiene styrene)
Sizes (ID)	$\frac{3}{8}$ " , $\frac{1}{2}$ "
Connections	HB-HB, HB-TC
Operating temperature range	4 - 40 °C
Operating pressure range	0 - 4 bar (g)
Recommended installation angle	10° - 45°
Chemical resistance (at 25°C)	Aqueous buffers (pH 1 - 13) for 24 h 1 M NaOH for 30 min 1 M HCl for 30 min 20% ethanol or isopropanol for 24 h 20% solutions for 1h: DMAc (N, N-dimethylacetamide), DMSO (dimethyl sulfoxide), DMF (N, N-dimethylformamide), PG (propylene glycol), ACN (acetonitrile), NMP (N-methyl-pyrrolidone)
Shelf-life	Prior to gamma/x-ray irradiation: 3 years After gamma/x-ray irradiation: 3 years

$\frac{3}{8}$ " TC-HB

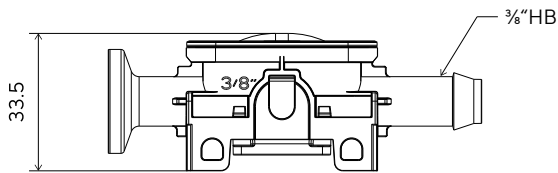

$\frac{3}{8}$ " HB-HB

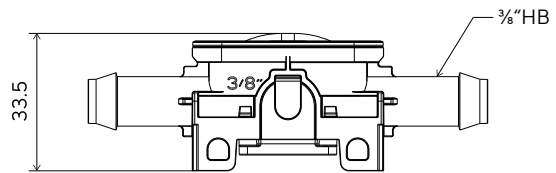

TC 25

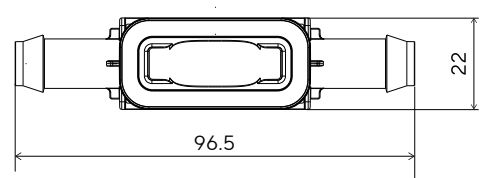
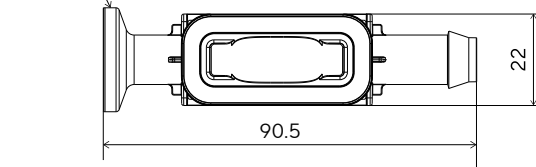

$\frac{1}{2}$ " TC-HB

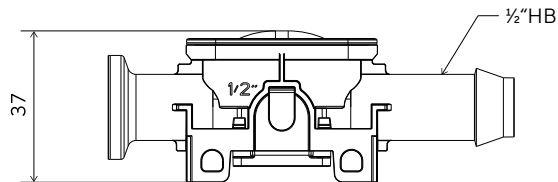

$\frac{1}{2}$ " HB-HB

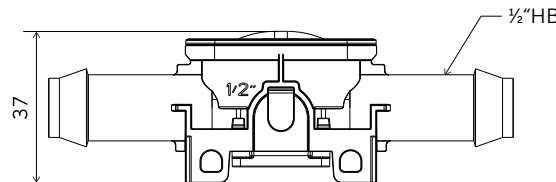

TC 25

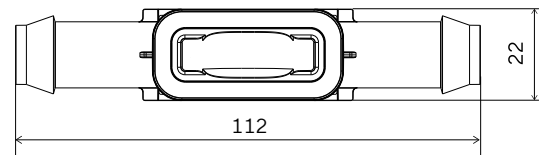
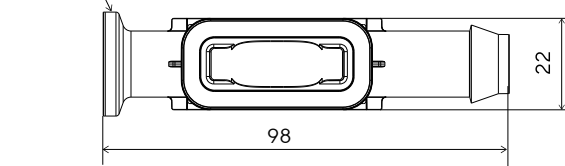

Dimensions in mm.

Spectrometer

Dimensions	305 × 234 × 75 mm
Material	Powder-coated aluminum case
IP-Code	20
Power Supply	24 V
Interface	Profinet
Light Source	Xenon flash lamp, guaranteed > 1 x 10 ⁸ flashes. e.g. with 20 ms default flash interval setting equivalent to 555 h of continuous use
Connections	
Optical	2 F-SMA-905, twist proof
Electrical	M12, 4-pol.
Data	RJ45

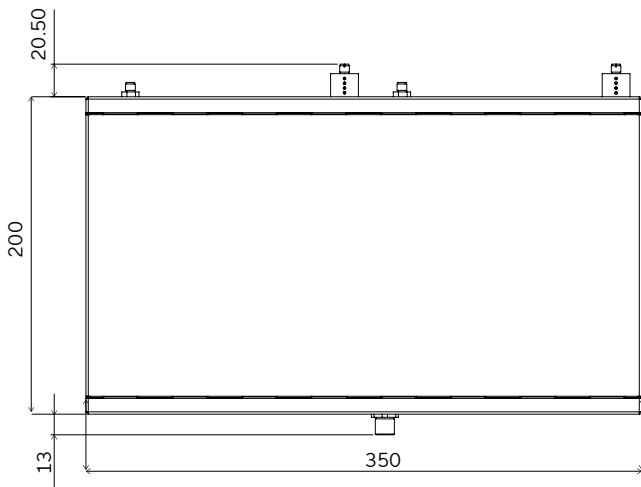

----- Only used for 2-channel spectrometers

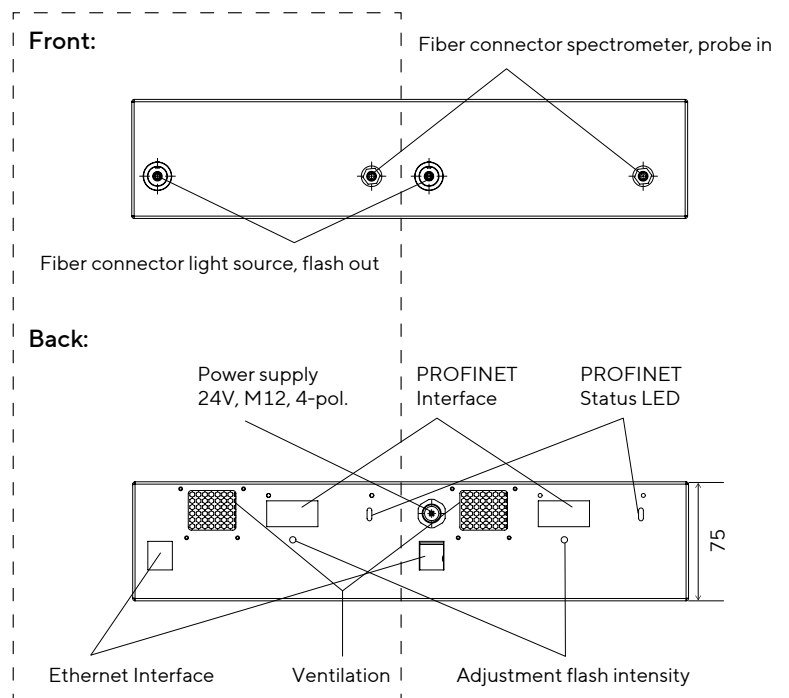

Dimensions in mm.

Probe Head

Material	Anodized aluminum
IP-Code	65
Dimensions	103 × 42 × 30 mm
Glass fiber length	Approx. 1.3 m
Minimum bending radius	50 mm
Connections	2 F-SMA-905, twist proof
Range	225–380 nm

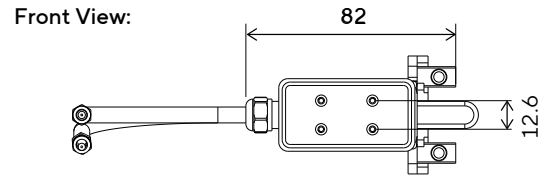

Side View: Min. bending radius of optical fiber:
50 mm according to probe manual

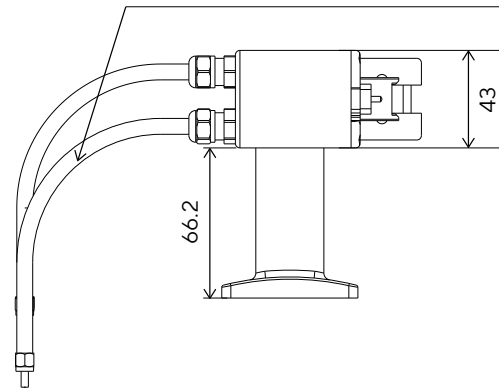

Calibration Pipe

Material	PU (polyurethan); Quartz; EPDM
Connections	Female Luer
Intended use	The calibration pipe is designed for reference measurements only. It should not be used for in-process measurement and should be discarded after one day or one consecutive set of reference measurements.

Verification Kit

Scope of delivery	Reference material set: <ul style="list-style-type: none">▪ UV5: Rare earth in perchloric acid (Holmium)▪ UV14: Perchloric acid▪ UV10: Sodium iodide▪ UV12: Water▪ UV6: Toluene in hexane▪ UV9: Hexane▪ UV20, UV60, UV120: Potassium dichromate (20, 60 and 120 mg/L)▪ UV35: Rare earth in perchloric acid (Cerium)▪ Cuvette holder▪ Calibration certificates
Dimensions (transport case)	Approx. 29.6 × 21.2 × 9.6 cm
Storing shipping conditions	15 – 30 °C (keep away from light and dust, in non-condensating humidity conditions in the original transport case and delivered insolation package)

Stand-Alone Kit

Scope of delivery	Self-adhesive rubber feet power supply 24 V split ferrits
-------------------	---

Ordering Information

Single-Use Pipes*

Product Description	Order Number
BioPAT® Spectro UV pipe 3/8" HB-TC	BPS0321
BioPAT® Spectro UV pipe 1/2" HB-TC	BPS0421
BioPAT® Spectro UV pipe 3/8" HB-HB	BPS0331
BioPAT® Spectro UV pipe 1/2" HB-HB	BPS0431

* The BioPAT® Spectro UV single-use pipes can only be ordered in multiples of 10 units.

Hardware

Product Description	Order Number
BioPAT® Spectro UV Spectrometer EC 1 channel	BPS1110
BioPAT® Spectro UV Spectrometer EC 2 channel	BPS1120
BioPAT® Spectro UV Probe**	BPS1200

** 1 unit required per channel in the spectrometer.

Accessories

Product Description	Order Number
BioPAT® Spectro SU UV Calibration pipe	BPS1300
BioPAT® Spectro UV Instrument Verification Kit	BPS1301
Stand-alone pack for BioPAT® Spectro UV	BPS1302

Germany

Sartorius Stedim Biotech GmbH
August-Spindler-Strasse 11
37079 Goettingen
Phone +49 551 308 0

USA

Sartorius Stedim North America Inc.
565 Johnson Avenue
Bohemia, NY 11716
Toll-Free +1 800 368 7178



For further information, visit

www.sartorius.com