

BioPAT® Pinch Valve

For Flow Control and
Open | Close Applications



Product Information

The BioPAT® Pinch Valve is an innovative valve solution for flow rate control and open | close applications. It consists of an electrical drive, a valve body and an installation set. Tubing can easily be installed and secured in the valve, without have to deal with loose parts. The BioPAT® Pinch Valve is available in three sizes A, B and C, achieving more flexibility for tubing sizes through the different installation sets available.

Benefits

- Re-opening mechanism
- Non-product contacting
- Robust and accurate electrical drive
- Gentle on the tubing
- Available for tube diameters ranging from 1/8" to 1" ID

Benefits of Using the BioPAT® Pinch Valve

- Re-opening mechanism
 - A purposely designed feature promotes re-opening of pinched tubing, even after long periods being closed.
- Non-product contacting
 - The BioPAT® Pinch Valve requires no dedicated single-use component, reducing cost of the single-use assemblies. Additionally, there is no direct contact with the process stream.
- Gentle on the tubing
 - The components of the BioPAT® Pinch Valve were specially designed to minimize damage of the tubing during pinching.
- Robust and accurate electrical drive
 - The fully electrical drive operates independent of availability of pressurized air. A step motor, with an initialization protocol, allows for very accurate positioning of the valve moving parts, independent of valve or tubing size. The PROFINET interface allows for a higher degree of automation in the integration of the BioPAT® Pinch Valve.

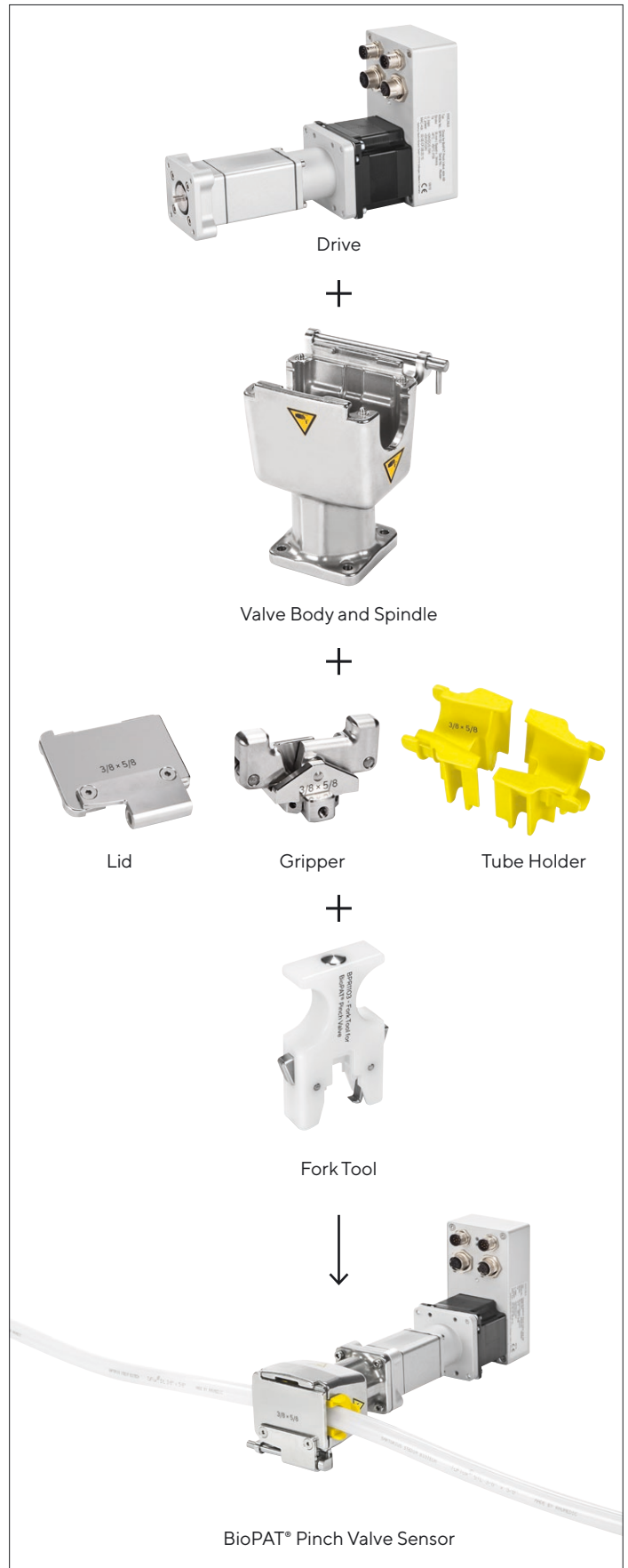

Working Principle

Once the tubing is correctly installed in the BioPAT® Pinch Valve and the lid is close, the degree of “openness” of the tubing can be controlled by moving the gripper and spindle connected to the motor in the drive towards or away from the lid (Figure 2).

To open the tube again, the drive pulls the shaft and the gripper deeper into the body, while the gripper is slightly closing to bring the tube back to its original form. For more information about different closing conditions and possibilities, see the Operation Instruction of the system.

Re-opening Mechanism

The re-opening mechanism is a purposely designed feature in the BioPAT® Pinch Valve gripper to promote the re-shaping of the tube cross-section after long periods being closed. To open the tubing, the levers on the gripper push the walls of the tubing inwards, while the spindle and gripper move away from the lid (Figure 2).



Position	Definition	Description
0%	Fully close	Defined during the initialization of the valve as the maximum distance the motor can travel without installed tubing
5% - 23%	Closing point-secure (CPS)	Position at which the tubing is fully close. Dependent on tubing type and size. Pre-configured in the control unit software.
32% - 71%	Opening point (OP)	Position at which the tubing is open enough to achieve X% of the flow rate. Dependent on tubing type and size.
100%	Fully open	Defined during the initialization of the valve as the minimum distance the motor can travel without installed tubing

Figure 2: Working Principle Schematics of the BioPAT® Pinch Valve

Electrical Drive

The BioPAT® Pinch Valve is controlled by an electrical drive. The step motor allows for high accuracy and robustness of the positioning of the valve. The electrical drive is available in two sizes, the smaller is used with BioPAT® Pinch Valve sizes A and B, and the bigger size with BioPAT® Pinch Valve sizes B.

It can be integrated into the Sartorius single-use upstream and downstream bioprocessing systems, through the Profinet® interface. The digital interface allows for a more comprehensive integration, control and flexibility of the BioPAT® Pinch Valve, as well as for better monitoring of maintenance status of the motor itself.

Qualified Tubing Types and Pressures

The BioPAT® Pinch Valve has been qualified for use with the following tube types and sizes:

BioPAT® Pinch Valve Size	Tubing Size ID × OD	Raumedic TuFlux® SIL ¹	Dow Corning® Pharma 50 ²	Sani-Tech® STHT®-R ³	C-Flex® 374 ³
A	⅛" × ¼"	■	■	-	■
	¼" × ⅜"	■	■	-	■
	¼" × ⅞"	■	■	-	■
B	⅜" × ⅝"	■	■	■	■
	½" × ¾"	■	■	-	■
	½" × ⅞"	-	-	■	-
C	¾" × 1"	■	■	-	■
	¾" × 1 ⅛"	■	■	■	-
	1" × 1 ⅜"	-	-	■	-

The operation of the BioPAT® Pinch Valve with the different tubing types and sizes was qualified up to the following operating pressure in the tubing:

Tubing ID	⅛"	¼"	⅜"	½"	¾"	1"
Raumedic TuFlux® SIL ¹	2.0 bar				1.0 bar	
Dow Corning® Pharma 50 ²	1.5 bar			1.0 bar		
Sani-Tech® STHT®-R ³			5.0 bar	3.0 bar		
C-Flex® 374 ³			1.0 bar			

Flow Curves, Open and Closing Points

Each tubing type and size has a characteristic curve that relates the position of the BioPAT® Pinch Valve to the flow rate allowed by the valve. Figure 1 depicts, as an example, the characteristic flow curve for Tuflux® Sil ½" × ¾", with a BioPAT® Pinch Valve size B, with the corresponding installation-set size. Additionally, it is also shown the absolute pressure generated by the valve, at each position of the BioPAT® Pinch Valve. The characteristic flow curves for all qualified tube types and sizes are available on-demand. To obtain this information, please contact our sales office.

Average Flow Rate Measurement ⅛" × ¼" Tuflux®-SIL

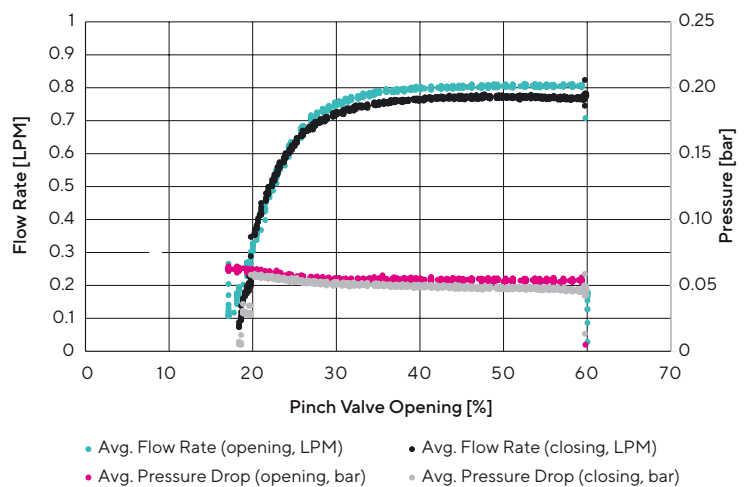

Figure 3: Characteristic Flow Rate and Pressure Drop Curves for Tuflux® Sil ⅛" × ¼" With a BioPAT® Pinch Valve size B, With the Corresponding Installation-Set Size, in the 'Opening' and the 'Closing' Travel Trajectories.

ID: inner diameter; OD: outer diameter

¹ Tuflux® is a registered Trademark of Sartorius Stedim Biotech GmbH

² Dow Corning® is a registered Trademark of Dow Corporate

³ Sani-Tech and C-Flex are registered Trademarks of Saint-Gobain

Performance Plastics Corporation

The table below summarizes the opening points and closing points-secure positions, in percentage, for all tube types and sizes currently qualified for the BioPAT® Pinch Valve.

BioPAT® Pinch Valve Size	Tubing Size ID × OD	Raumedic TuFlux® SIL ¹		Dow Corning® Pharma 50 ²		Sani-Tech® STHT®-R ³		C-Flex® 374 ³	
		OP	CPS	OP	CPS	OP	CPS	OP	CPS
A	1/8" × 1/4"	39.0	17.3	46.2	18.2	-	-	40.9	16.9
	1/4" × 3/8"	46.5	17.8	42.2	18.3	-	-	47.6	18.2
	1/4" × 7/16"	51.7	21.4	48.8	23.1	-	-	52.8	21.0
B	3/8" × 5/8"	39.8	7.1	35.4	8.1	45.0	13.1	35.8	9.1
	1/2" × 3/4"	51.4	5.1	44.3	7.6	-	-	32.7	8.4
	1/2" × 7/8"	-	-	-	-	71.0	18.9	-	-
C	3/4" × 1"	45.0	8.4	54.0	8.7	-	-	50.0	9.0
	3/4" × 1 1/8"	46.0	10.3	50.0	10.1	51.0	8.3	-	-
	1" × 1 3/8"	40.0	12.4	-	-	51.0	11.8	-	-

Closing Speed and Forces

The force required to control the degree of opening of the BioPAT® Pinch Valve is dependent on the tube type and size as well as the operating pressure in the tubing. As an example, figure 4 shows the force curves for the different sizes of Tuflux® Sil. The characteristic force curves for all qualified tube types are available on-demand. To obtain this information, please contact our sales office.

The force required to pinch the tubing then has an impact on the maximum speed at which the electrical drive can operate. The electrical drives for the BioPAT Pinch Valve® achieve at least 5 mm/s, independent of the force required, for the qualified tube types and sizes. For more information please contact your application specialist.

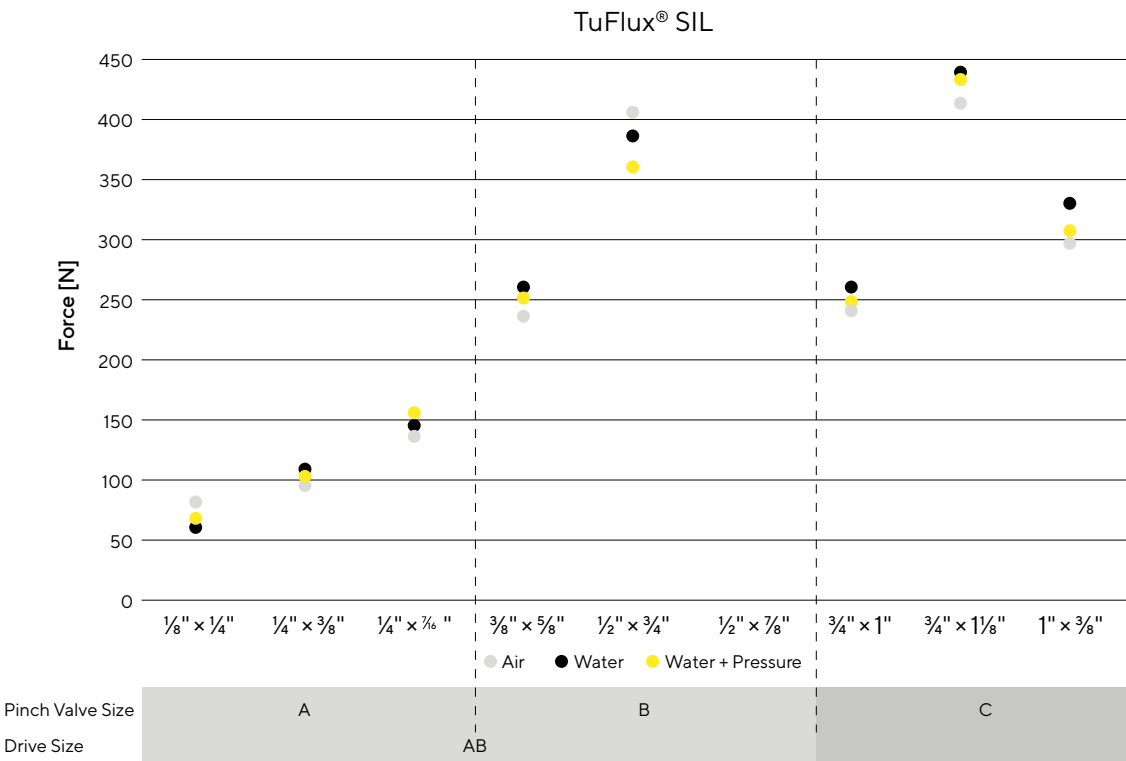

Figure 4: Characteristic Force Curves for Tuflux® Sil.

Particle | Qualification and Quality Assurance

When tubes are subjected to pinching, automatized or manual, they undergo a deformation which can result on release of visible and | or subvisible particles. During the qualification of BioPAT® Pinch Valve, the release of subvisible particles was tested according to Ph. Eur. 2.9.19 and USP <788>. All sizes of BioPAT® Pinch Valves with all sizes of tubing types successfully withstand the acceptance criteria.

Additionally, for informational purposes the release of visible particles was investigated. For critical applications, e.g. fill and finish, it is recommended to integrate the BioPAT® Pinch Valve followed by a particle removal filter. For more information please contact your application specialist.

Maintenance Interval

Life Time

The different components of the BioPAT® Pinch Valve have been qualified for different lifetimes depending on their functions.

- Tubing: 300 pinches at the same position on the tubing without position adjustment, without losing performance
- Installation Set: 1.45 km use-distance or 25,000 cycles
- BioPAT® Pinch Valve Body: 7.25 km use-distance or 125,000 cycles
- Electrical Drive: 14.5 km use-distance or 2,000 operating hours

Technical Specifications

Electrical Drive

	Unit	Value															
Temperature	°C	+4 - +40															
Maximal Speed	mm/s	3 (at max. force)															
Position Repeatability	mm	±0.1															
Connections		<ul style="list-style-type: none"> ▪ X1 I/O Port ▪ X2 Power I/O Port ▪ X3 X4 Ethernet 															
Material		Anodized aluminum and Stainless Steel															
Dimensions	mm	<table border="1" style="width: 100%; border-collapse: collapse;"> <thead> <tr> <th></th> <th>Size A&B</th> <th>Size C</th> </tr> </thead> <tbody> <tr> <td>H</td> <td>120.5</td> <td>120.5</td> </tr> <tr> <td>W</td> <td>60</td> <td>60</td> </tr> <tr> <td>L</td> <td>198</td> <td>252.5</td> </tr> <tr> <td>X</td> <td>M5</td> <td>M6</td> </tr> </tbody> </table>		Size A&B	Size C	H	120.5	120.5	W	60	60	L	198	252.5	X	M5	M6
	Size A&B	Size C															
H	120.5	120.5															
W	60	60															
L	198	252.5															
X	M5	M6															
IP-Code		IP 54															
Supply Voltage		24 V DC (±20%)															

	Unit	Value						
Pinch Valve Drive Size		<table border="1" style="width: 100%; border-collapse: collapse;"> <thead> <tr> <th></th> <th>A&B</th> <th>C</th> </tr> </thead> <tbody> <tr> <td>Maximal Feed Force</td> <td> <ul style="list-style-type: none"> ▪ 450 (nominal) ▪ 500 (at duty cycle < 20%) ▪ 600 (at duty cycle < 5%) </td> <td> <ul style="list-style-type: none"> ▪ 50 (nominal) ▪ 850 (at duty cycle < 20%) ▪ 1,000 (at duty cycle < 5%) </td> </tr> </tbody> </table>		A&B	C	Maximal Feed Force	<ul style="list-style-type: none"> ▪ 450 (nominal) ▪ 500 (at duty cycle < 20%) ▪ 600 (at duty cycle < 5%) 	<ul style="list-style-type: none"> ▪ 50 (nominal) ▪ 850 (at duty cycle < 20%) ▪ 1,000 (at duty cycle < 5%)
	A&B	C						
Maximal Feed Force	<ul style="list-style-type: none"> ▪ 450 (nominal) ▪ 500 (at duty cycle < 20%) ▪ 600 (at duty cycle < 5%) 	<ul style="list-style-type: none"> ▪ 50 (nominal) ▪ 850 (at duty cycle < 20%) ▪ 1,000 (at duty cycle < 5%) 						
Weight	Kg	1.2						

Drawing: Pinch Valve Drive Size A&B

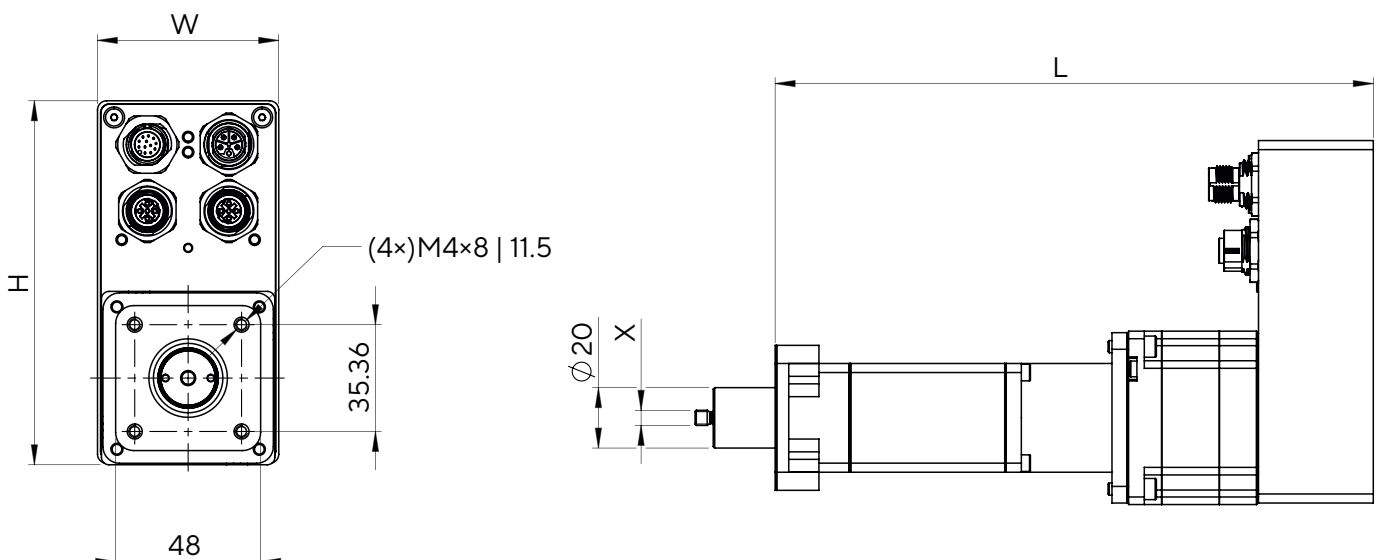

Valve Body and Installation Sets

	Unit	Value		
Material		Stainless Steel		
Head Dimensions	mm	Size A	Size B	Size C
H		66.5	94	132
W		55.3	67.7	86
L		50	65	84
Weights	kg	Size A	Size B	Size C
BioPAT® Pinch Valve		0.602	1.014	1.776
Installation Sets		0.122	0.207	0.45
Ambient Conditions				
Temperature	°C	+4 - +40		
Approved Cleaning Agents				
Isopropyl Alcohol Solution	%	70		
Ethanol Solution	%	70		
Neutral cleaning solutions, e.g. Prolystica® Ultra Concentrate HP Neutral Detergent ¹				

Drawing: Body & Gripper

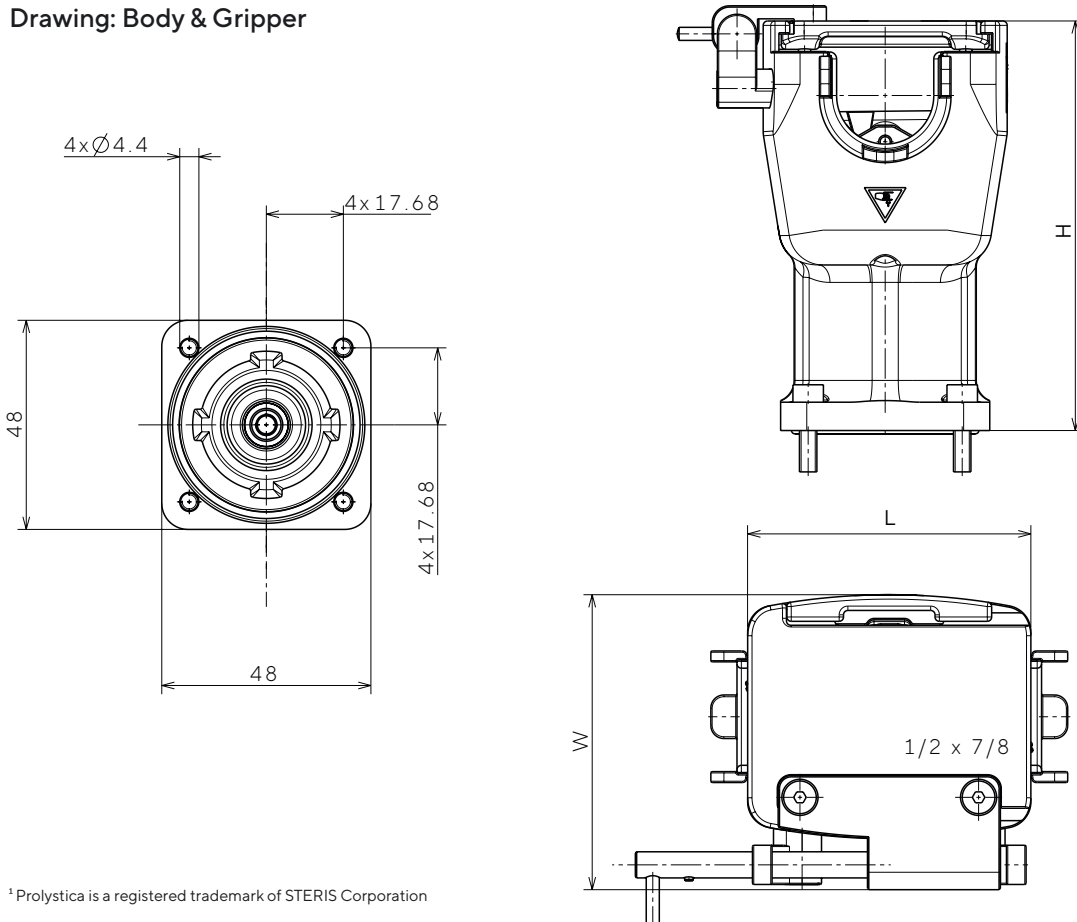

¹ Prolystica is a registered trademark of STERIS Corporation



Ordering Information

Electrical Drive

Item	Order Number
Drive for BioPAT® Pinch Valve, Size A & B	BPR1101
Drive for BioPAT® Pinch Valve, Size C	BPR1102

Valve Body

Item	Description	Order Number
BioPAT® Pinch Valve, Size A	$\frac{1}{4}$ " x $\frac{7}{16}$ "	BPR1006
	$\frac{1}{4}$ " x $\frac{3}{8}$ "	BPR1007
	$\frac{1}{8}$ " x $\frac{1}{4}$ "	BPR1008
BioPAT® Pinch Valve, Size B	$\frac{1}{2}$ " x $\frac{7}{8}$ "	BPR1003
	$\frac{1}{2}$ " x $\frac{3}{4}$ "	BPR1004
	$\frac{3}{8}$ " x $\frac{5}{8}$ "	BPR1005
BioPAT® Pinch Valve, Size C	1" x $1\frac{3}{8}$ "	BPR1000
	$\frac{3}{4}$ " x $1\frac{1}{8}$ "	BPR1001
	$\frac{3}{4}$ " x 1"	BPR1002

Installation Set

Consisting of 1 gripper, 1 lid and 2 tube holders specific for the required tubing size.

Item	Description	Order Number
BioPAT® Pinch Valve Installation Set for size A	$\frac{1}{4}$ " x $\frac{7}{16}$ "	BPR1015
	$\frac{1}{4}$ " x $\frac{3}{8}$ "	BPR1016
	$\frac{1}{8}$ " x $\frac{1}{4}$ "	BPR1017
BioPAT® Pinch Valve Installation Set for size B	$\frac{1}{2}$ " x $\frac{7}{8}$ "	BPR1012
	$\frac{1}{2}$ " x $\frac{3}{4}$ "	BPR1013
	$\frac{3}{8}$ " x $\frac{5}{8}$ "	BPR1014
BioPAT® Pinch Valve Installation Set for size C	1" x $1\frac{3}{8}$ "	BPR1009
	$\frac{3}{4}$ " x $1\frac{1}{8}$ "	BPR1010
	$\frac{3}{4}$ " x 1"	BPR1011

Accessories

Item	Order Number
Fork Tool for BioPAT® Pinch Valve	BPR1103

Germany

Sartorius Stedim Biotech GmbH
August-Spindler-Strasse 11
37079 Goettingen
Phone +49 551 308 0

USA

Sartorius Stedim North America Inc.
565 Johnson Avenue
Bohemia, NY 11716
Toll-Free +1 800 368 7178

 **For more information, visit**
www.sartorius.com