

BioPAT® Flow

Accurate and Flexible
Flow Measurement From
Process Development to
Commercial Production



Product Information

The in-line flowmeters of the BioPAT® Flow family provide the right fit for all scales of your bioprocess. They were the world's first ultrasonic-flowmeter clamp-ons that are used with single-use flow pipes, resulting in flexibility and higher accuracy than conventional clamp-ons that measure directly on the tube (see comparison data in Figure 5 and Figure 6). BioPAT® Flow can be used both as real-time flowmeters and volume totalizers.

Features and Benefits

- Non-invasive, ultrasonic flow measurement
- World's most accurate single-use ultrasonic flow clamp-on
- Available for tube diameters ranging from ¼" to 1" ID
- Independent of fluid viscosity and system pressure
- Temperature compensation from 4–37 °C

The integration of the flow sensor is fast and easy. The flow pipes can be integrated into any single-use tube assembly without introducing bends or changing the inner diameter. The clamp-on transmitter is then simply fixed around the pipe (Figure 1) and the measurement can take place.

The sensors of the BioPAT® Flow family are highly chemically resistant and compatible with a broad spectrum of liquids with respect to viscosity, opaqueness, corrosiveness and temperature.

Benefits of Using a Flow Pipe

The BioPAT® Flow sensors are the world's only ultrasonic flow meter clamp-ons that use a single-use flow pipe instead of measuring directly on the pipe. This innovation comes with several advantages.

- **Higher accuracy** than measurements on tubes through optimized coupling, rigid material and a straight flow path.
- **High reproducibility.** Other than tubes, the flow pipes do not have deviations in their wall thickness, which enhances the reproducibility of the measurement.
- **High chemical resistance** compatible with ADC applications.
- **Pressure independence.** Measurement is highly independent of pressure changes as the rigid flow pipe material doesn't expand or collapse. High pressure applications with up to 5 bar(g) are possible.
- **Versatile applications.** The flow pipes can be connected to all types of tubes with a certain inner diameter, even to reinforced tubing tubes. Conventional clamp-on flowmeters require an extra calibration for every tube material and thickness used.
- **Clearly defined measurement position** as the flow pipe is integrated at a defined position in the tube system. This reduces the risks of operator errors and lower accuracy due to incorrect positioning.

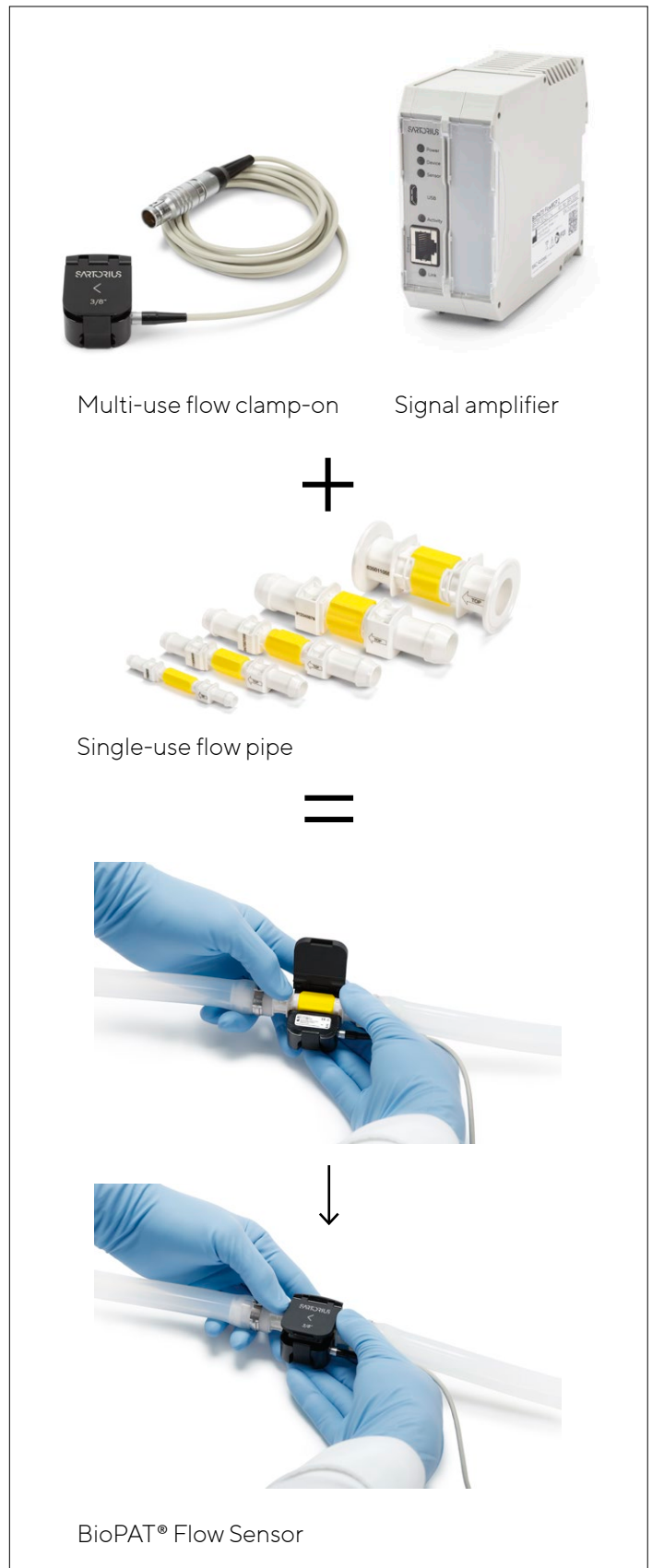

Figure 1: The Biopat® Flow Sensor Is the Combination of a Single-Use Flow Pipe and a Multi-Use Clamp-On.

Measurement Principle

The BioPAT® Flow sensors use the ultrasonic transit-time technology to accurately and quickly determine the flow rate. Figure 2 depicts the measurement principle. Inside the flow clamp-on two pairs of sensors function both as a source and a detector for ultrasound waves. The sensor pairs are oriented diagonally in the corners of the clamp-on. Each sensor sends a wave to its opposite partner. The waves travel through the flowing liquid at a certain angle, such that they either travel downstream and are accelerated by the flow stream or they travel upstream and are decelerated by the flow stream. This leads to a transit time difference between the two signals that is proportional to the flow velocity, from which the flow rate can be calculated using the inner diameter of the flow pipe. To increase measurement accuracy, the two sensor pairs measure the transit time difference simultaneously.

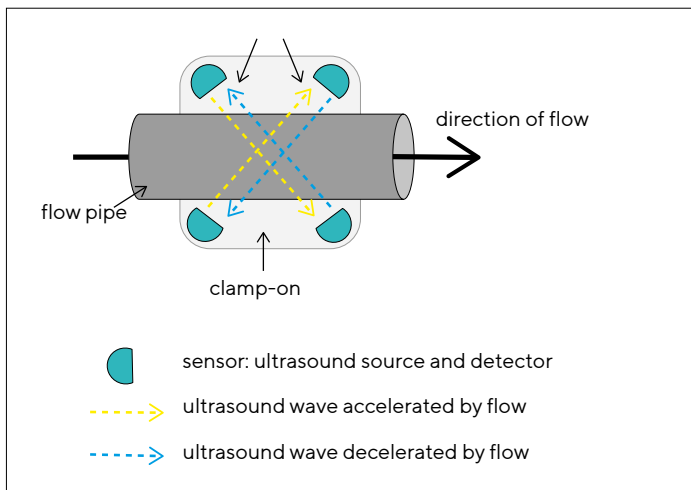

Figure 2: The BioPAT® Flow Sensors Use Ultrasonic Transit Time Technology to Determine the Flow Rate.

Data Read-Out

The BioPAT® Flow sensors can be read-out using different options:

- **Sartorius Bioprocessing Systems.** The sensors are fully integrated in the hardware and software of the Sartorius single-use upstream and downstreams platforms, for example Flexact® Modular or Resolute® Flowdrive SU.
- **BioPAT® Flowplus** Signal amplifier for stand-alone applications. It allows direct read out of flow rate signal and simple configuration actions (zeroing, calibration table selection, etc.). Signals can also be further transferred to an external control unit.
- **BioPAT® FlowMCP** Signal amplifier for integration into electrical cabinets, Available in 1, 2 or 4 parallel channel versions. Modbus TCP interface. Connection cables should be ordered separately (see Order Information).

Please note that Sartorius does not provide a stand-alone software for the flow sensor. Software integration is only given with Sartorius bioprocessing systems.



Figure 3: BioPAT® FlowMCP (Left) And BioPAT® Flowplus (Right).

Compatibility Matrix

The BioPAT® FlowMCP introduces a new generation to the BioPAT® Flow family, with a more modern interface. To guarantee the same technical performance the software configuration of the BioPAT® Flow Clamp-ons had to be adjusted. For this purpose, a new set of clamp-ons is available. The BioPAT® Flow single-use pipes are compatible with both hardware generations. For more information, please consult Order Information.

Influence of Process Conditions

Temperature

Variations in temperature have a significant influence on the ultrasonic flow measurement, as it changes both the viscosity of the flowing liquid and the velocity of the ultrasonic waves. BioPAT® Flow sensors offers three standard calibration tables¹, stored in every clamp-on, that ensure the highest accuracy in three common working temperature ranges:

- Chilled solutions: 4–14 °C
- Room temperature: 17–27 °C
- Heated solutions: 27–37 °C

As an example, figure 5 shows the worst observed accuracy value over a flow rate range between 30% and 100% Q_{max} tested at different temperatures. When using the BioPAT® Flow single-use pipe in comparison to a measurement directly on the flexible tubing, the accuracy achieved is considerably better and less impacted by the temperature.

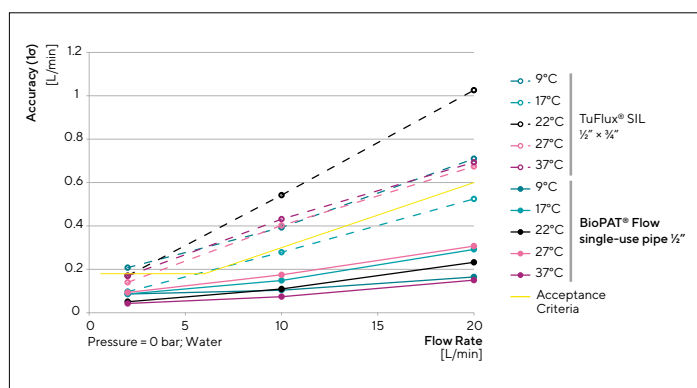

Figure 5: BioPAT® Flow Sensors Show Consistent Performance and High Accuracy Over a Wide Temperature Range.

Pressure

The influence of pressure on the flow measurement is minimal, thanks to the design and material of the flow pipes. Figure 6 shows how, in comparison to a measurement directly on flexible tubing, by using the BioPAT® Flow single-use pipe, the accuracy is not affected by changes in pressure.

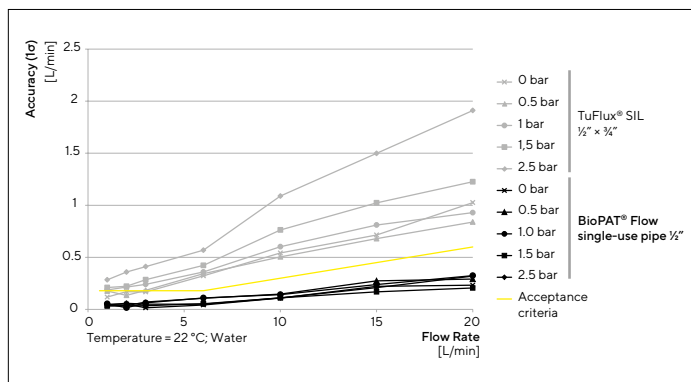

Figure 6: The BioPAT® Flow Shows Reproducibility Over a Wide Pressure Range.

Composition of The Liquid Stream

The standard calibration tables for BioPAT® Flow use water as calibration fluid. The measurement accuracy remains unaffected by changes in homogeneity, turbidity and viscosity of the flowing liquids for the large majority of the solutions/suspensions used in biomanufacturing processes. The stated accuracy has been confirmed for:

- Aqueous solutions (e.g. buffer solutions)²
- Protein suspensions (BSA 200 g/L)
- Particles suspensions (diatomaceous earth 50 g/L)
- Cell suspensions (baker’s yeast 80 g/L dry weight)

For more challenging solutions, for example, high concentration buffers, it is recommended to carry out preliminary studies, in order to assess if the standard calibration tables are suitable for the specific application. If not, it is recommended to use a customized calibration table (BPL0056, see Order Information) or a dynamic correction factor. For more information, please contact our technical support.

¹ Not applicable to BPL0030, -31 and -32. For more information, please consult the BioPAT® FlowMCP Operating Instructions.

² Approx. density <1.01 g/ml or conductivity <20 mS/cm (equiv. to ~175 mM NaCl)

³ The system accuracy is calculated as 1-Sigma accuracy (mean deviation to reference measurement + 1 standard deviation) and is valid for the usage of any clamp-on transmitter with any single-use flow pipe component, providing the good practices for integration were complied with. The integration into bioprocessing systems and respective single-use assemblies can have a detrimental impact on the accuracy of the measurement. Please consult the good practices for installation and operation (see Operating instructions) or contact our technical support.

Sensor Integration Into SU Assemblies

Proper installation of the BioPAT® flow sensor ensures a reliable and accurate ultrasonic measurement. When installing the sensor into a single-use assembly, it is important to position the sensor so that the pipe is always filled with liquid and does not run dry or catch air bubbles. This can be achieved by positioning the sensor at a low position. Integration suggestions are presented in Figure 4. Furthermore, it is recommended a straight inlet path length (see Technical Specifications).

Especially when the integration of BioPAT® Flow is planned next to a pump, the recommended position for the sensor is on the suction side. This avoids loss of signal quality due to localized and temporary presence of air bubbles on the discharge side of the pump.

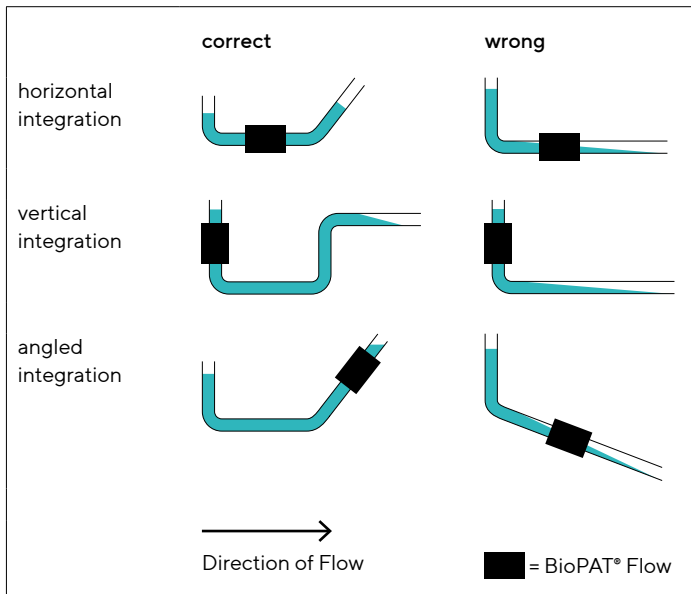

Figure 4: Recommended Installation of the BioPAT® Flow Clamp-On.

Measurement Range and Accuracy

Size (ID)	Maximum flow rate (Q_{max}) [L/min]	System accuracy ³	
		3 – 30% Q_{max}	30 – 100% Q_{max}
¼" (6.35 mm)	4.167 ¹	0.06 L/min	5% c.v.
⅜" (9.53 mm)	10 ¹	0.09 L/min	3% c.v.
½" (12.7 mm)	20 ¹	0.18 L/min	3% c.v.
¾" (19.05 mm)	50	0.45 L/min	3% c.v.
1" (25.40 mm)	76.67	0.69 L/min	3% c.v.

c.v. = current value

Q_{max} = upper end of measurement range, maximal flow-rate

As shown in figure 7, the BioPAT® Flow family covers a wide range of flow rates up to 76.67 L/min.

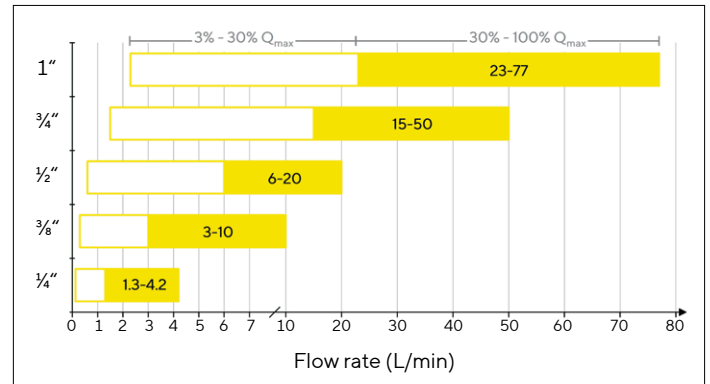

Figure 7: Overview of the Measurement Range Covered by the Members of the BioPAT® Flow Family. The Optimal Flow Range (30% – 100% Q_{max}) Resulting in the Highest Accuracy, Is Represented as the Solid Bars.

Sensor Transfer Sets

The BioPAT® Flow sensors can be purchased as configured sensor transfer-sets for functional filtration units. The sensors are part of a comprehensive single-use and advanced analytics portfolio that provides robust and reliable measurements of critical process parameters and enables highly automated single-use bioprocessing within your design space.

Qualification and Quality Assurance

All products from the BioPAT® Flow family comply with the quality and safety requirements of typical biopharmaceutical processes. Full batch traceability and quality control assure that the single-use flow pipes follow the directives and guidelines of the relevant regulatory agencies.

A comprehensive testing procedure includes, among others:

- extractable studies
- EMA/410/01 compliance
- RoHs/REACH compliance
- non-cytotoxic (according to ISO-10993-1, -5, -12 and USP <88>Class VI)

Technical Specifications

Single-Use Pipes

Material	In contact with product: PBT (polybutylene terephthalate) Other: TPE (thermoplastic elastomer, styrene block copolymer based)
Operating temperature range	4–37 °C
Operating pressure range	0–5 bar (g)
Minimum inlet path length	$\frac{3}{4}$" ID: 10 × ID $\geq \frac{3}{4}</math>" ID: 15 × ID$
Chemical resistance ¹	1M NaOH at 40 °C for 2 h 20% solutions at 25 °C for 1h of: DMAc (N,N-dimethylacetamide), DMSO (Dimethyl sulfoxide), DMF (N,N-dimethylformamide), PG (Propylene glycol), ACN (acetonitrile), NMP (N-methyl-pyrrolidone)
Shelf-life	Prior to gamma irradiation: 3 years. After gamma irradiation: 3 years

ID = inner diameter

¹ tested in 1 year aged irradiated pipes

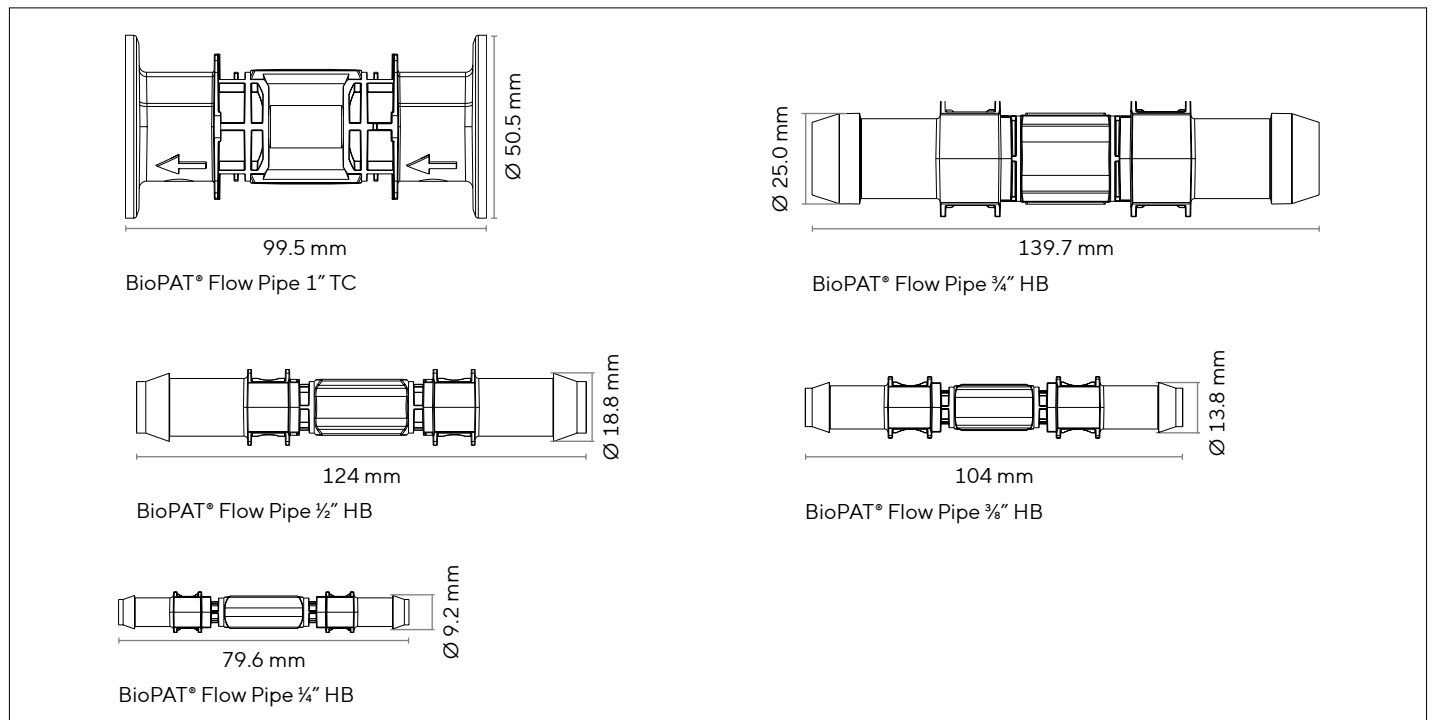

Figure 8: Overview of the Single-Use Flow Pipes.

Clamp-Ons

Material	Epoxy resin, aluminium, brass: ¼", ⅜", ½" Polymeric compound, aluminium, brass: ¾", 1"
Head dimensions (H×W×L)	¼": 25×33×45 mm, ⅜": 25×33×45 mm, ½": 27×38×51 mm, ¾": 35×43×69 mm, 1": 46×56×84 mm
Cable length	0.3 or 2.9 m (see Order Information)
IP-Code	IP65
Calibration tables	Supplied with 3 standard calibration tables ¹ : 4-14 °C 17-27 °C 27-37 °C Different calibration tables can be additionally installed (see Ordering Information - Accessories). One sensor can store up to 7 calibration tables.
Calibration frequency	Every 2 years (advisable) On-site adjustments and recalibration services are available on request. For more information, please contact our Technical Support Services.
Cleaning and disinfection	Clean and disinfect using alcohol based surface cleaners

Signal Amplifiers

Housing dimensions (H×W×L)	BioPAT® Flowplus: 65×110×140 mm BioPAT® FlowMCP 1/2 ch.: 99×45×115 mm BioPAT® FlowMCP 4 ch.: 99×90×115 mm
Housing material	Aluminum
IP-Code	BioPAT® Flowplus: IP 65 BioPAT® FlowMCP: IP20
Supply voltage	24 V DC (± 10%) via power adaptor or external supply
Interface types	BioPAT® Flowplus: Digital (RS-232) or Analogue (4-20 mA, flow rate and signal strength: RSS) BioPAT® FlowMCP: Modbus TCP RS-232 4-20 mA analogue: Flow and received signal strength (RSS)

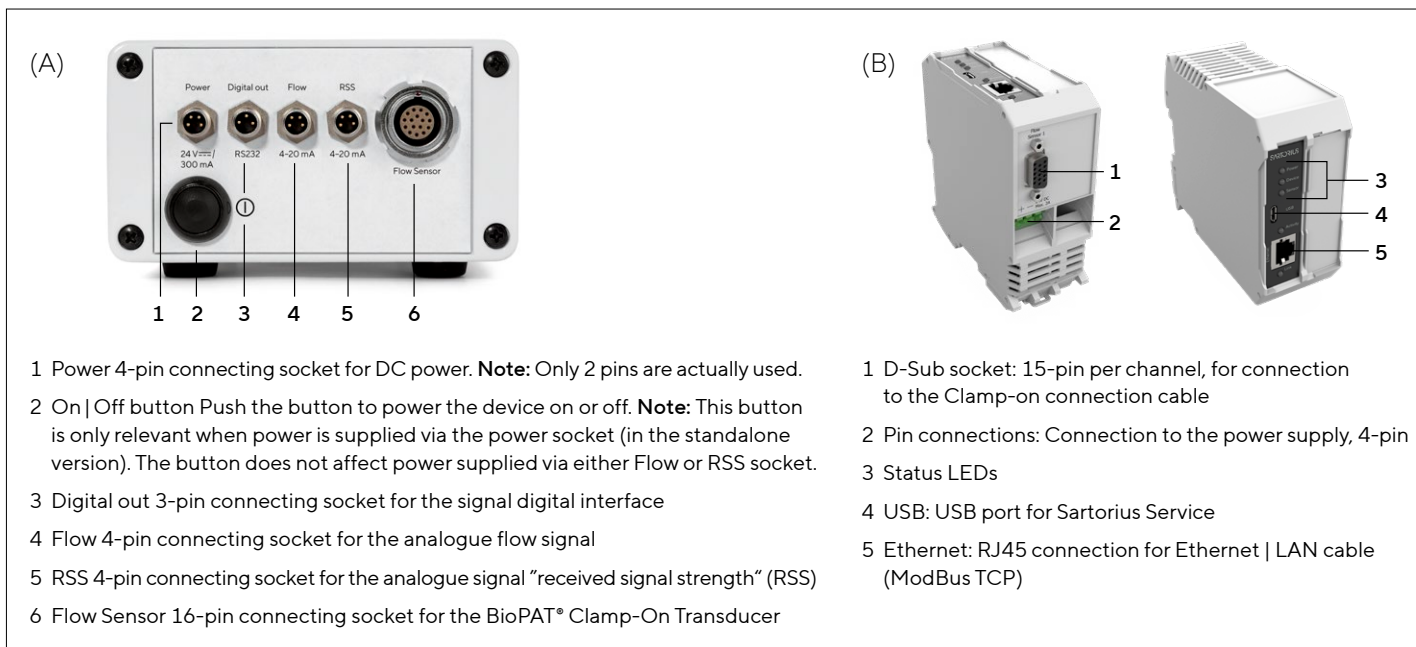

Figure 9: (A) *Electronic Connections on BioPAT® Flowplus Signal Amplifier.*
(B) *Electronic Connections on BioPAT® FlowMCP.*

Ordering Information

Single-Use Pipes

Order Number	Size	Connection
BPL0121	¼" (6.35 mm)	Hose barb
BPL0111	⅜" (9.53 mm)	Hose barb
BPL0101	½" (12.7 mm)	Hose barb
BPL0151	¾" (19.05 mm)	Hose barb
BPL0131	1" (25.4 mm)	Tri-clamp

Note: The BioPAT® Flow single-use pipes can only be ordered in multiples of 10 units.

For your convenience, the BioPAT® Flow single-use pipes are also available in fully configurable, pre-assembled, sterile and ready-to-use assemblies. For more information please consult the "Single-Use Filtration and Sensor Solutions" Brochure, the Data Sheet "Filter & Sensor Transfer Sets" or contact our sales office.

Signal Amplifiers

Order Number	Description
BPL0002	BioPAT® Flowplus - Benchtop signal amplifier with display
BPL0301	BioPAT® FlowMCP 1 ch. - 1 channel signal amplifier for integration into electrical cabinets
BPL0302	BioPAT® FlowMCP 2 ch. - 2 channels signal amplifier for integration into electrical cabinets
BPL0304	BioPAT® FlowMCP 4 ch. - 4 channels signal amplifier for integration into electrical cabinets

Clamp-Ons

For BioPAT® Flowplus

Order Number	Size	Cable Length (cm)
BPL0010	¼" (6.35 mm)	290
BPL0011	⅜" (9.53 mm)	290
BPL0012	½" (12.7 mm)	290
BPL0028	¾" (19.05 mm)	290
BPL0013	1" (25.4 mm)	290

For BioPAT® FlowMCP

Order Number	Size	Cable Length (cm)
BPL0310	¼" (6.35 mm)	30
BPL0311	⅜" (9.53 mm)	30
BPL0312	½" (12.7 mm)	30
BPL0313	¾" (19.05 mm)	30
BPL0314	1" (25.4 mm)	30
BPL0330	¼" (6.35 mm)	290
BPL0331	⅜" (9.53 mm)	290

For quotation of BioPAT® Flow Clamp-ons for direct reading on the tubing please contact our sales office.

Services

Order Number	Description
BPL0056	BioPAT® Flow customized calibration table*

Additional information needs to be provided. Please contact our technical support for details.

*Order as many as the number of clamp-ons that should be delivered or updated with a customized calibration table.

Accessories

Order Number	Description
BPL0200	Connection cable for BioPAT® Flowplus - digital interface (RS232)
BPL0201	Connection cable for BioPAT® Flowplus - analog interface (4-20 mA)
BPL0204	Adapter cable for BioPAT® Flowplus - USB<>RS232
BPL0203	Connection cable for BioPAT® FlowDIN - digital interface (RS232)
BPL0202	Extension cable for BioPAT® FlowDIN, 1.10 m, IP50
BPL0212	Extension cable for BioPAT® FlowDIN, 2.65 m, IP50
BPL0207	Switchmode Power supply
BPL0208	Type C (EUR) plug adapter for Power Supply
BPL0209	Type G (UK) plug adapter for Power Supply
BPL0210	Type A&B (US/JP) plug adapter for Power Supply
BPL0211	Type D&M (IEC) plug adapter for Power Supply
BPL0215	Type I (AUS) plug adapter for Power Supply
BPL0213	Extension cable for BioPAT® FlowMCP 1-4, 1.10 m, IP50
BPL0214	Extension cable for BioPAT® FlowMCP 1-4, 2.65 m, IP50
BPL0217	Protection cap for extension cable BioPAT® FlowMCP with IP68
BPL0218	Extension cable for BioPAT® FlowMCP 1-4, 1.10 m, IP68
BPL0219	Extension cable for BioPAT® FlowMCP 1-4, 2.65 m, IP68

Please consult the respective Operating Instructions for guidance on the accessories.

Compatibility Matrix for Order Information

	No. of channels	Interface	Clamp-ons	Visual differences
BioPAT® Flowplus BPL0002	1	Analog (4 - 20 mA) Digital (RS232)	BPL0010 BPL0011 BPL0012 BPL0028 BPL0013 BPL0030 BPL0031 BPL0032	old branding
BioPAT® FlowMCP BPL0301 BPL0302 BPL0204	1, 2 or 4	MODBUS TCP	BPL0310 BPL0311 BPL0312 BPL0313 BPL0314 BPL0330 BPL0331 BPL0332 BPL0333 BPL0334	new branding

Germany

Sartorius Stedim Biotech GmbH
August-Spindler-Strasse 11
37079 Goettingen
Phone +49 551 308 0

USA

Sartorius Stedim North America Inc.
565 Johnson Avenue
Bohemia, NY 11716
Toll-Free +1 800 368 7178

 For further contacts, visit
www.sartorius.com